



AB-TS12LS-230VO + AB-TS12DT-230VI

Job Name: _____
Location: _____
Engineer: _____
Submitted to: _____
Submitted by: _____
Reference: _____

Date: _____
Approval: _____
Construction: _____
Unit #: _____
Drawing #: _____

KEY FEATURES:

- Slim Duct Single-Zone System
- Inverter Technology
- Bluefin Coating Protection
- Wi-Fi Wall Thermostat Included
- Built-in Drain Pump
- Two Return Mode Options

NOTES:

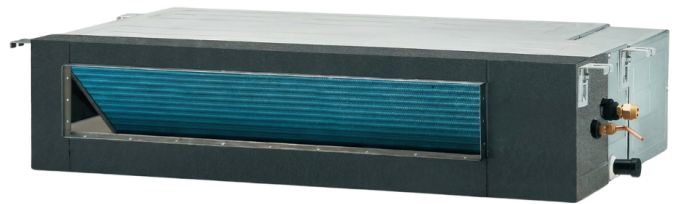



AB-TS12LS-230VO + AB-TS12DT-230VI

Indoor Model			AB-TS12DT-230VI
Power supply		V, Ph, Hz	208-230, 1PH, 60HZ
Communication wiring			AWG 16x4
Cooling	Capacity	Btu/h	12,000 (2000~12300)
	Input	w	940
	Rated current	A	4.1
	EER/EER2	Btu/w	9.5
	SEER/SEER2	Btu/w	20.0
Heating at 47 °F	Capacity	Btu/h	3100~12300
	Input	W	1030
	Rated current	A	4.5
	COP	W/W	3.34
	HSPF4/HSPF2-4		9.5
	HSPF5/HSPF2-5		7.3
Indoor fan motor	Qty		1
	Input		50
	RLA		0.23
Indoor air flow (Turbo/Hi/Med/Lo) (No duct)		CFM	360/330/270/217/194
ESP (range)		In.wg.	0-.04 In.W.G
Indoor noise level (Hi/Med/Lo)		dB(A)	44/41/35/33/32
Dehumidification		L/H	3.38
Indoor unit	Dimensions (WxDxH)	inch	27 -1/2"×17 -3/4"×7 -7/8"
	Packing (WxDxH)	inch	35 -3/8"×21 -7/8"×9 -7/8"
	Net/Gross weight	lbs	33.1
Drainage water pipe diameter		inch	0.63
Refrigerant piping (Liquid side/Gas side)		inch	1/4" 3/8"
Design pressure		PSIG	609/174
Controller			Wired Controller
Room temperature	Cooling	F	62~89
	Heating	F	32~86



AB-TS12LS-230VO + AB-TS12DT-230VI

Outdoor Model		AB-TS12LS-230VO	
Power supply		V, Ph, Hz	208-230, 1PH, 60HZ
Min. circuit ampacity		A	11
Max. fuse		A	15
Compressor	Model		WMO98SJ72-B01
	Type		Rotary
	Brand		Rechi
	Capacity	Btu/h	11942
	Input	w	875
	Rated current (RLA)	A	0.15
	Refrigerant oil	oz	8.12
Outdoor fan motor	Qty		1
	Input	w	33
	RLA	A	0.15
	Speed	r/min	1000
Outdoor air flow (Max)		CFM	900
Outdoor noise level (Max)		dB(A)	55
Throttle type			Capillary
Outdoor unit	Dimensions (WxDxH)	inch	31 -1/2"x12"x21 -3/4"
	Packing (WxDxH)	inch	32 -7/8"x13 -3/8"x23"
	Net/Gross weight	inch	51.8
Refrigerant	Type		R32
	Precharge	ft	25
Additional charge for 1/4 inch liquid pipe		oz	0.11
Additional charge for 3/8 inch liquid pipe		oz	
Refrigerant piping	Liquid side/Gas side	inch	1/4" 3/8"
	Max. pipe length	ft	49
	Max. difference in level	ft	33
Ambient temperature	Cooling	F	5~127
	Heating	F	-4~75



AB-TS12LS-230VO + AB-TS12DT-230VI

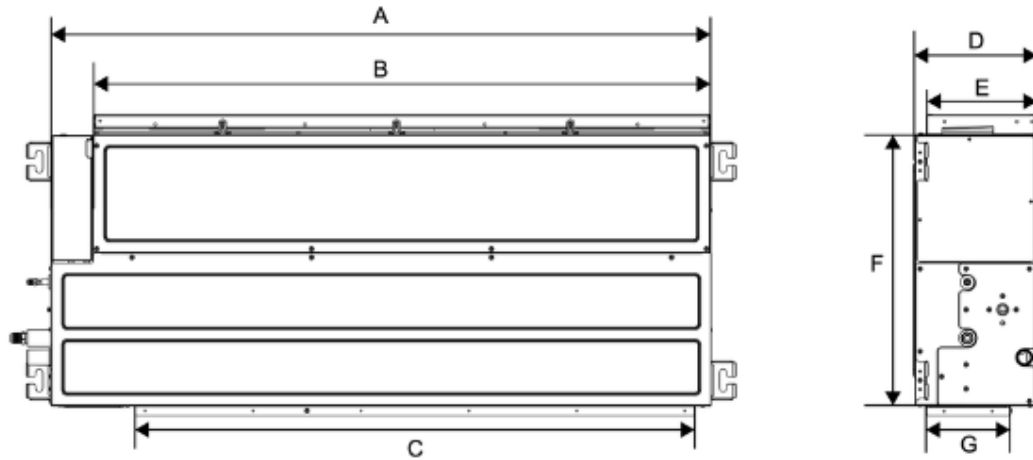

Unit: mm

Model	Indoor unit						
	A	B	C	D	E	F	G
9K-12K	700	600	513	200	189	452	146
18K	920	820	733	200	189	452	146
24K	1100	1030	934	200	189	452	146

Unit: in

Model	Indoor unit						
	A	B	C	D	E	F	G
9K-12K	27.6	23.6	20.2	7.9	7.4	17.8	5.7
18K	36.2	32.3	28.8	7.9	7.4	17.8	5.7
24K	43.3	40.5	36.8	7.9	7.4	17.8	5.7

INSTALLATION SPACE

Diagram of installation location and space for indoor unit (Notice: for the best performance of indoor unit, make sure its installation space conforms to the following installation dimensions).

Unit:mm

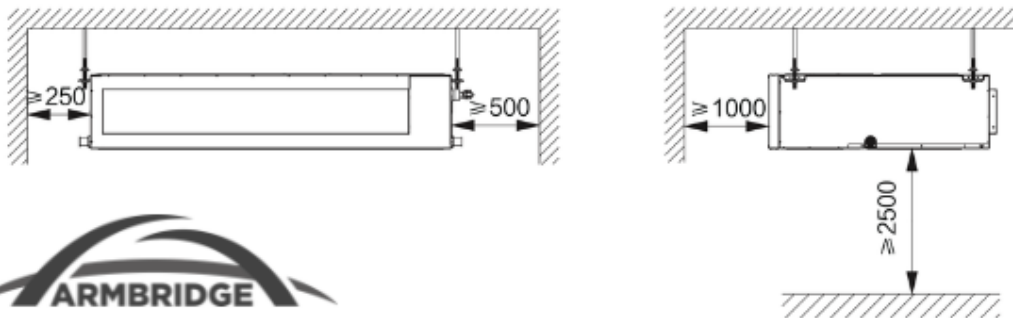



AB-TS12LS-230VO + AB-TS12DT-230VI

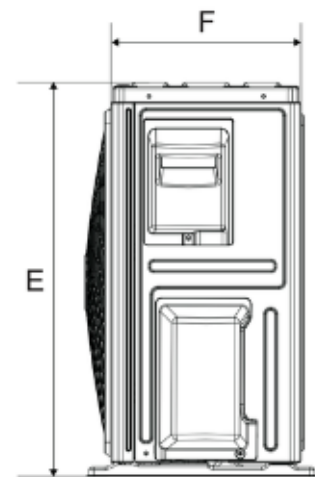
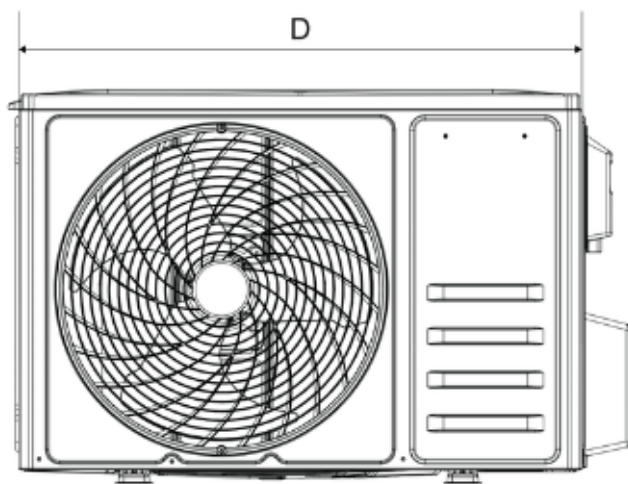
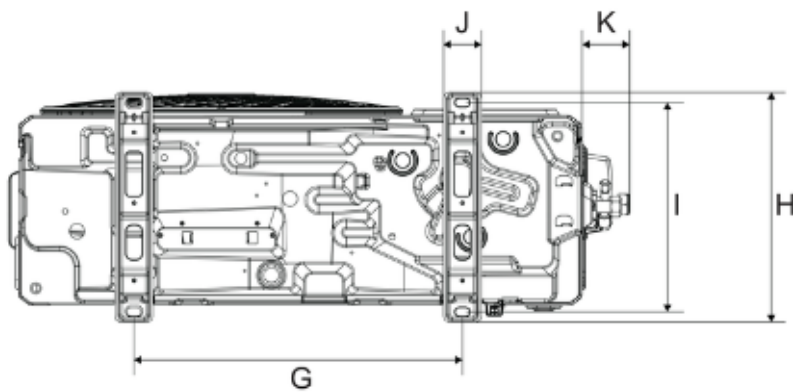

Unit: mm

Model	Outdoor unit							
	D	E	F	G	H	I	J	K
9K	721	498	240	415	290	263	48	59
12K	742	551	257	434	305	278	48	59
18K	794	602	292	516	349	314	54	58
24K	843	700	330	586	375	348	59	48

Unit: in

Model	Outdoor unit							
	D	E	F	G	H	I	J	K
9K	28.4	19.6	9.44	16.3	11.4	10.4	1.9	2.3
12K	29.2	21.7	10.1	17.1	12.0	10.9	1.9	2.3
18K	31.2	23.7	11.5	20.3	13.7	12.4	2.1	2.3
24K	33.1	27.5	13.0	23.1	14.8	13.7	2.3	1.9