



AB-TS24LS-230VO + AB-TS24WM-230VI

Job Name: _____

Location: _____

Engineer: _____

Submitted to: _____

Submitted by: _____

Reference: _____

Date: _____

Approval: _____

Construction: _____

Unit #: _____

Drawing #: _____

KEY FEATURES:

- High-efficiency Inverter Technology for consistent comfort and energy savings
- Uses environmentally friendly R32 refrigerant for improved performance
- AHRI and ETL listed
- Wide operating range for reliable heating and cooling performance
- Advanced airflow control for even temperature distribution
- Smart Sync Built-In
- Wall Mount Single-Zone System
- 16' Line Set and Drain Lines, 21' Communication Cable Included

NOTES:

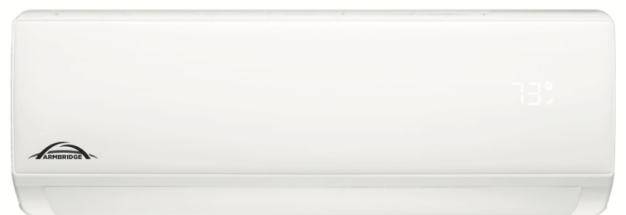



AB-TS24LS-230VO + AB-TS24WM-230VI

Indoor Model			AB-TS24WM-230VI
Power supply		V, Ph, Hz	208-230, 1PH, 60HZ
Communication wiring			AWG 16x4
Cooling	Capacity	Btu/h	24,000 (7500~36000)
	Input	w	2250
	Rated current	A	9.8
	EER/EER2	Btu/w	10.5
	SEER/SEER2	Btu/w	20.0
Heating at 47 °F	Capacity	Btu/h	5100~26000
	Input	W	2450
	Rated current	A	10.7
	COP	W/W	2.8
	HSPF4/HSPF2-4		9.5
	HSPF5/HSPF2-5		8.1
Indoor fan motor	Qty		1
	Input		60
	RLA		0.20
Indoor air flow (Turbo/Hi/Med/Lo) (No duct)		CFM	647/575/517/423/382
ESP (range)		In.wg.	
Indoor noise level (Hi/Med/Lo)		dB(A)	51/49/43/37/34
Dehumidification		L/H	5.49
Indoor unit	Dimensions (WxDxH)	inch	39 -3/4"×8 -5/8"×12 -3/8"
	Packing (WxDxH)	inch	43 -1/8"×11 -3/4"×15 -3/8"
	Net/Gross weight	lbs	33.7
Drainage water pipe diameter		inch	0.63
Refrigerant piping (Liquid side/Gas side)		inch	1/4" 1/2"
Design pressure		PSIG	609/174
Controller			Remote Controller
Room temperature	Cooling	F	63~90
	Heating	F	32~81



AB-TS24LS-230VO + AB-TS24WM-230VI

Outdoor Model			AB-TS24LS-230VO
Power supply		V, Ph, Hz	208-230, 1PH, 60HZ
Min. circuit ampacity		A	20
Max. fuse		A	30
Compressor	Model		C-6RZ180H3BAF
	Type		Rotary
	Brand		SANYO
	Capacity	Btu/h	20199
	Input	w	1410
	Rated current (RLA)	A	0.37
	Refrigerant oil	oz	15.22
Outdoor fan motor	Qty		1
	Input	w	85
	RLA	A	0.37
	Speed	r/min	850
Outdoor air flow (Max)		CFM	1412
Outdoor noise level (Max)		dB(A)	60
Throttle type			EEV
Outdoor unit	Dimensions (WxDxH)	inch	36 -1/8"x14 -3/4"x27 -1/2"
	Packing (WxDxH)	inch	37 -3/8"x16 -1/2"x28 -7/8"
	Net/Gross weight	inch	88.2
Refrigerant	Type		R32
	Precharge	ft	25
Additional charge for 1/4 inch liquid pipe		oz	0.11
Additional charge for 3/8 inch liquid pipe		oz	
Refrigerant piping	Liquid side/Gas side	inch	1/4" 1/2"
	Max. pipe length	ft	65
	Max. difference in level	ft	49
Ambient temperature	Cooling	F	5~127
	Heating	F	-4~75



AB-TS24LS-230VO + AB-TS24WM-230VI

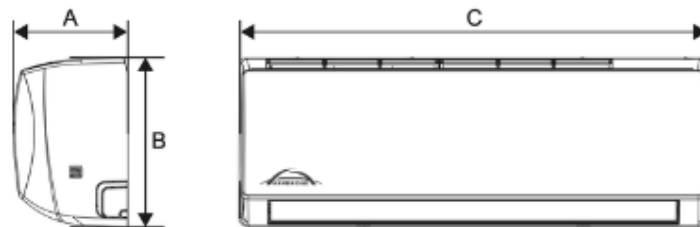

Model	Indoor unit		
	A	B	C
9-12K	198mm/7.79in	292mm/11.49in	811mm/31.92in
18K	206mm/8.11in	295mm/11.61in	909mm/35.78in
24K	220mm/8.66in	315mm/12.40in	1010mm/39.76in
36K	258mm/10.15in	360mm/14.17in	1191mm/46.88in



AB-TS24LS-230VO + AB-TS24WM-230VI

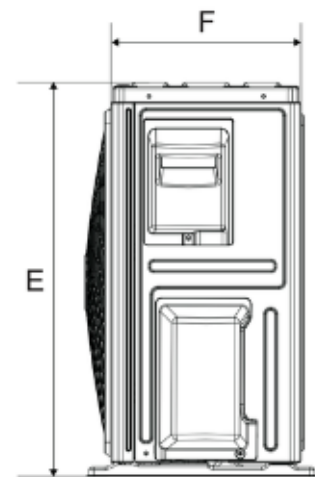
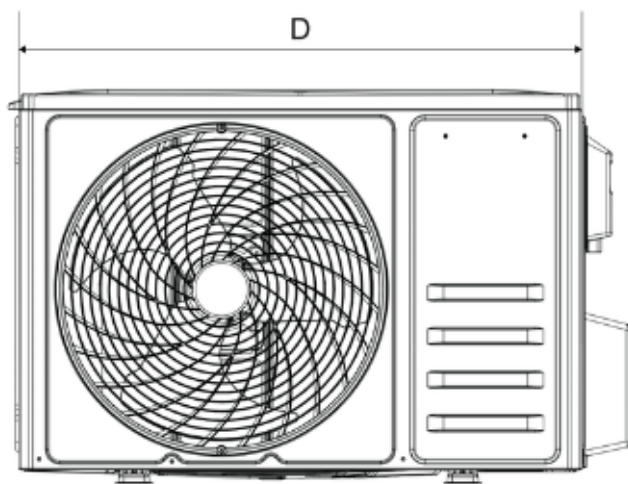
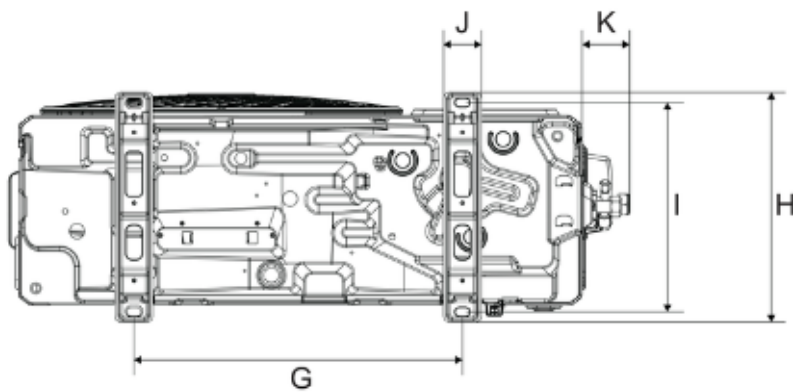

Unit: mm

Model	Outdoor unit							
	D	E	F	G	H	I	J	K
9K	721	498	240	415	290	263	48	59
12K	742	551	257	434	305	278	48	59
18K	794	602	292	516	349	314	54	58
24K	843	700	330	586	375	348	59	48

Unit: in

Model	Outdoor unit							
	D	E	F	G	H	I	J	K
9K	28.4	19.6	9.44	16.3	11.4	10.4	1.9	2.3
12K	29.2	21.7	10.1	17.1	12.0	10.9	1.9	2.3
18K	31.2	23.7	11.5	20.3	13.7	12.4	2.1	2.3
24K	33.1	27.5	13.0	23.1	14.8	13.7	2.3	1.9