



# AB-TS12LS-230VO + AB-TS12WM-230VI

**Job Name:** \_\_\_\_\_

**Location:** \_\_\_\_\_

**Engineer:** \_\_\_\_\_

**Submitted to:** \_\_\_\_\_

**Submitted by:** \_\_\_\_\_

**Reference:** \_\_\_\_\_

**Date:** \_\_\_\_\_

**Approval:** \_\_\_\_\_

**Construction:** \_\_\_\_\_

**Unit #:** \_\_\_\_\_

**Drawing #:** \_\_\_\_\_

## KEY FEATURES:

- High-efficiency Inverter Technology for consistent comfort and energy savings
- Uses environmentally friendly R32 refrigerant for improved performance
- AHRI and ETL listed
- Wide operating range for reliable heating and cooling performance
- Advanced airflow control for even temperature distribution
- Smart Sync Built-In
- Wall Mount Single-Zone System
- 16' Line Set and Drain Lines, 21' Communication Cable Included

## NOTES:

\_\_\_\_\_

\_\_\_\_\_

\_\_\_\_\_

\_\_\_\_\_

\_\_\_\_\_

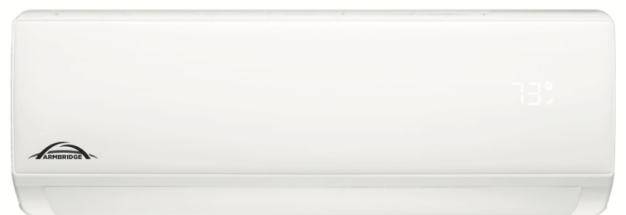



# AB-TS12LS-230VO + AB-TS12WM-230VI

Indoor Model			AB-TS12WM-230VI
Power supply		V, Ph, Hz	208-230, 1PH, 60HZ
Communication wiring			AWG 16x4
Cooling	Capacity	Btu/h	12,000 (2000~13900)
	Input	w	1240
	Rated current	A	5.4
	EER/EER2	Btu/w	9.5
	SEER/SEER2	Btu/w	20.0
Heating at 47 °F	Capacity	Btu/h	2000~13900
	Input	W	1125
	Rated current	A	4.9
	COP	W/W	3.3
	HSPF4/HSPF2-4		10
	HSPF5/HSPF2-5		8.5
Indoor fan motor	Qty		1
	Input		25
	RLA		0.12
Indoor air flow (Turbo/Hi/Med/Lo) (No duct)		CFM	342/270/235/200/152
ESP (range)		In.wg.	
Indoor noise level (Hi/Med/Lo)		dB(A)	45/42/35/30/28
Dehumidification		L/H	3.38
Indoor unit	Dimensions (WxDxH)	inch	31 -7/8"x7 -3/4"x11 -1/2"
	Packing (WxDxH)	inch	34 -7/8"x10 -7/8"x14 -3/8"
	Net/Gross weight	lbs	24.3
Drainage water pipe diameter		inch	0.63
Refrigerant piping (Liquid side/Gas side)		inch	1/4" 3/8"
Design pressure		PSIG	609/174
Controller			Remote Controller
Room temperature	Cooling	F	63~90
	Heating	F	32~81



# AB-TS12LS-230VO + AB-TS12WM-230VI

Outdoor Model			AB-TS12LS-230VO
Power supply		V, Ph, Hz	208-230, 1PH, 60HZ
Min. circuit ampacity		A	11
Max. fuse		A	15
Compressor	Model		WMO98SJ72-B01
	Type		Rotary
	Brand		Rechi
	Capacity	Btu/h	11942
	Input	w	875
	Rated current (RLA)	A	0.15
	Refrigerant oil	oz	8.12
Outdoor fan motor	Qty		1
	Input	w	33
	RLA	A	0.15
	Speed	r/min	1000
Outdoor air flow (Max)		CFM	900
Outdoor noise level (Max)		dB(A)	55
Throttle type			Capillary
Outdoor unit	Dimensions (WxDxH)	inch	31 -1/2"x12"x21 -3/4"
	Packing (WxDxH)	inch	32 -7/8"x13 -3/8"x23"
	Net/Gross weight	inch	51.8
Refrigerant	Type		R32
	Precharge	ft	25
Additional charge for 1/4 inch liquid pipe		oz	0.11
Additional charge for 3/8 inch liquid pipe		oz	
Refrigerant piping	Liquid side/Gas side	inch	1/4" 3/8"
	Max. pipe length	ft	50
	Max. difference in level	ft	33
Ambient temperature	Cooling	F	5~127
	Heating	F	-4~75



# AB-TS12LS-230VO + AB-TS12WM-230VI

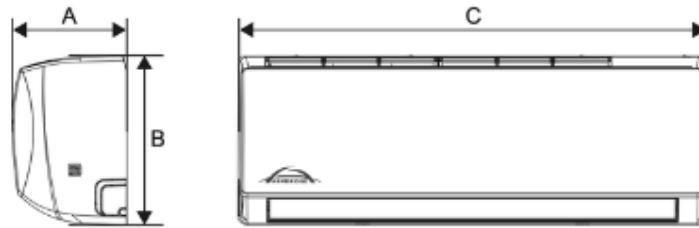

Model	Indoor unit		
	A	B	C
9-12K	198mm/7.79in	292mm/11.49in	811mm/31.92in
18K	206mm/8.11in	295mm/11.61in	909mm/35.78in
24K	220mm/8.66in	315mm/12.40in	1010mm/39.76in
36K	258mm/10.15in	360mm/14.17in	1191mm/46.88in



# AB-TS12LS-230VO + AB-TS12WM-230VI

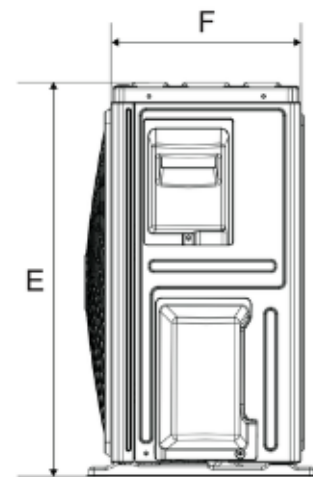
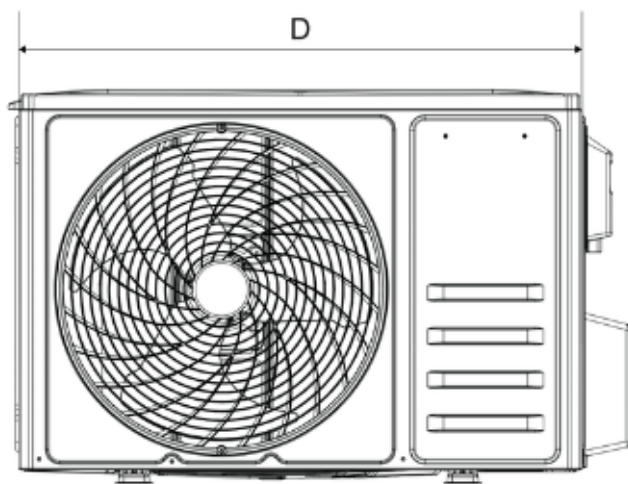
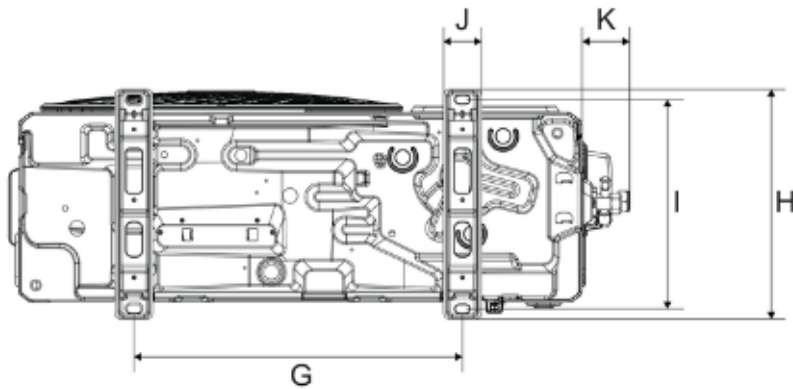

Unit: mm

Model	Outdoor unit							
	D	E	F	G	H	I	J	K
9K	721	498	240	415	290	263	48	59
12K	742	551	257	434	305	278	48	59
18K	794	602	292	516	349	314	54	58
24K	843	700	330	586	375	348	59	48

Unit: in

Model	Outdoor unit							
	D	E	F	G	H	I	J	K
9K	28.4	19.6	9.44	16.3	11.4	10.4	1.9	2.3
12K	29.2	21.7	10.1	17.1	12.0	10.9	1.9	2.3
18K	31.2	23.7	11.5	20.3	13.7	12.4	2.1	2.3
24K	33.1	27.5	13.0	23.1	14.8	13.7	2.3	1.9