



# OWNER'S MANUAL

---

## MODELS

---

AB-GTM09DT-230VI

AB-GTM12DT-230VI

AB-GTM18DT-230VI

AB-GTM24DT-230VI

**MULTI-ZONE SLIM DUCT**

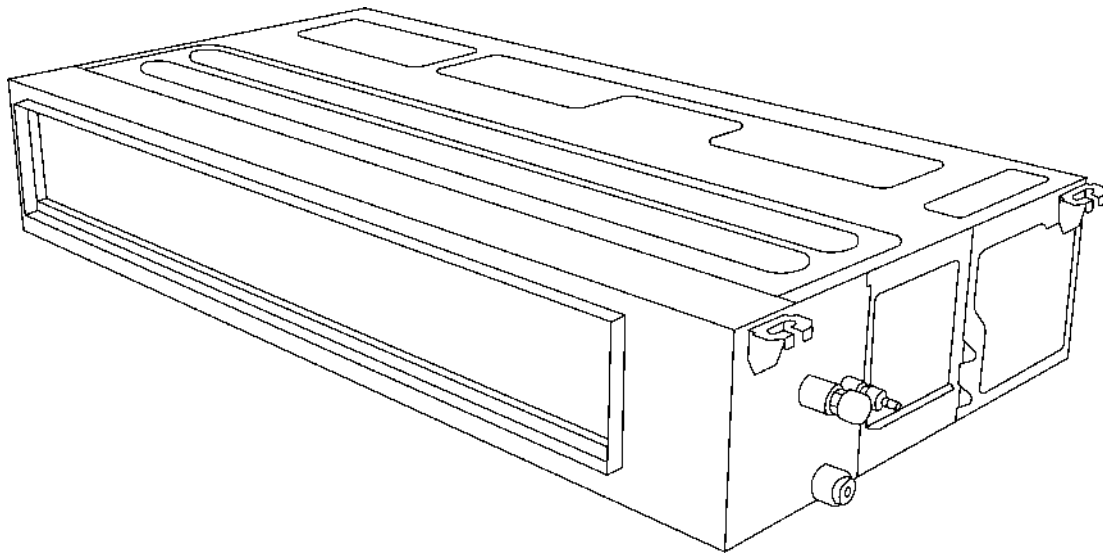

Please read this manual carefully and thoroughly before installing the unit.  
Take care of this manual for future reference.

# Contents

Warning .....	1
Safety Precautions .....	3
Notices for Usage .....	5
Notices for Installation .....	5
Installation Diagram .....	6
Before Operation Check List .....	7
Installation of the Indoor Unit .....	8
Electric Wiring Work .....	14
Testing and Inspection .....	17
Maintenance Notice .....	18
WIFI Control .....	21

**Note:**

- *All the illustrations in this manual are for explanation purpose only.*
- *Your air conditioner may be slightly different. The actual shape shall prevail.*
- *They are subject to change without notice for future improvement.*

# Warning

**NOTE : FCC and IC related content only applies to models with WiFi function.**

## ※ FCC WARNING

WARNING: Changes or modifications to this unit not expressly approved by the party responsible for compliance could void the user's authority to operate the equipment.

## ※ FCC STATEMENT

This device complies with Part 15 of the FCC Rules. Operation is subject to the following two conditions:

(1) this device may not cause harmful interference, and (2) this device must accept any interference received, including interference that may cause undesired operation.

NOTE: This equipment has been tested and found to comply with the limits for a Class B digital device, pursuant to part 15 of the FCC Rules. These limits are designed to provide reasonable protection against harmful interference in a residential installation. This equipment generates, uses and can radiate radio frequency energy and, if not installed and used in accordance with the instructions, may cause harmful interference to radio communications. However, there is no guarantee that interference will not occur in a particular installation. If this equipment does cause harmful interference to radio or television reception, which can be determined by turning the equipment off and on, the user is encouraged to try to correct the interference by one or more of the following measures:

- Reorient or relocate the receiving antenna.
- Increase the separation between the equipment and receiver.
- Connect the equipment into an outlet on a circuit different from that to which the receiver is connected.
- Consult the dealer or an experienced radio/TV technician for help.

## ※ IC STATEMENT

This device complies with Industry Canada licence exempt RSS standard(s).

Operation is subject to the following two conditions: (1) this device may not cause interference, and (2) this device must accept any interference, including interference that may cause undesired operation of the device.

Le présent appareil est conforme aux CNR d'Industrie Canada applicables aux appareils radio exempts de licence.





L'exploitation est autorisée aux deux conditions suivantes : (1) l'appareil ne doit pas produire de brouillage, et (2) l'utilisateur de l'appareil doit accepter tout brouillage radioélectrique subi, même si le brouillage est susceptible d'en compromettre le fonctionnement.

## ※ IC STATEMENT

This equipment complies with FCC's and IC's RF radiation exposure limits set forth for an uncontrolled environment. The antenna(s) used for this transmitter must be installed and operated to provide a separation distance of at least 7-7/8in.(20cm) from all persons and must not be collocated or operating in conjunction with any other antenna or transmitter. Installers must ensure that 7-7/8in.(20cm) separation distance will be maintained between the device (excluding its handset) and users.

Cet appareil est conforme aux limites d'exposition au rayonnement RF stipulées par la FCC et l'IC pour une utilisation dans un environnement non contrôlé. Les antennes utilisées pour cet émetteur doivent être installées et doivent fonctionner à au moins 7-7/8in.(20cm) de distance des utilisateurs et ne doivent pas être placées près d'autres antennes ou émetteurs ou fonctionner avec ceux-ci. Les installateurs doivent s'assurer qu'une distance de 7-7/8in.(20cm) sépare l'appareil (à l'exception du combiné) des utilisateurs.

# Warning

Symbol	Note	Explanation
 A2L	WARNING	This symbol shows that this appliance uses a flammable refrigerant. If the refrigerant is leaked and exposed to an external ignition source, there is a risk of fire. (Only for the AC with UL or ETL-MARKING, UL60335-2-40)
	CAUTION	This symbol shows that the operation manual should be read carefully.
	CAUTION	This symbol shows that a service personnel should be handling this equipment with reference to the installation manual.
	CAUTION	This symbol shows that information is available such as the operating manual or installation manual.

**NOTE:**

***The Air conditioner with R32 refrigerant, if roughly treated, may cause serious harm to the human body or surrounding things.***

- The room space and maximum refrigerant charge requirements are shown in the table to the right.
- If ice has formed on the unit, do not use means to accelerate the defrosting process other than those recommended by the manufacturer.
- Do not use any cleaners on the unit other than what's approved by the manufacture.
- Do not pierce or burn air conditioner and ensure that the refrigerant pipeline is not damaged.
- The appliance must be stored in a room without continuously operating ignition sources (for example: open flames, an operating gas appliance or an operating electric heater).
- Notice that the refrigerant may be odorless.
- The storage of the air conditioner should be in a location that's able to prevent unintentional damage to the unit.
- Be sure to follow all local codes and safety requirements.

**Room Space and Maximum Refrigerant Charge Requirements**

Refrigerant Type	Allowable Refrigerant Charge Amount, (oz(kg))	Min. Floor Area For Installation, (ft <sup>2</sup> (m <sup>2</sup> ))
R32	< 64.9 (< 1.84)	75.35 (7)
	64.9~82.54 (1.84~2.34)	96.88 (9)
	82.58~100.18 (2.341~2.84)	113.02 (10.5)
	100.21~117.82 (2.841~3.34)	134.55 (12.5)
	117.85~135.45 (3.341~3.84)	150.69 (14)
	135.49~153.09 (3.841~4.34)	193.75 (18)

# Safety Precautions

Incorrect installation or operation by not following these instructions may cause harm or damage to people, properties, etc. The seriousness is classified by the following indications:

 **WARNING**

This symbol indicates the possibility of death or serious injury.

 **CAUTION**

This symbol indicates the possibility of injury or damage to properties.

 **Things you shouldn't do.**

 **Follow the instructions.**

 **Cut the power off.**

 **Environmental notices.**

 **WARNING** 

- **Don't** connect the ground wire to the gas pipeline, water pipeline, lightning rod, or telephone earth wire.
- **Don't** pull the power cable. Pulling the power cable could result in damage to the unit and electrical shock.
- **Don't** cut off main power switch during operating or with wet hands. It may cause electric shock.
- **Don't** let the air conditioner blow against the heater appliance. Otherwise it will lead to incomplete combustion, thus causing poisoning.
- **Don't** let the remote control and the indoor unit watered or being too wet. Exposure to excessive moisture may cause damage to the unit and or electrical shock.
- **Don't** install the air conditioner in a place where there is flammable gas or liquid unless the distance is equal to or greater than 3-1/4ft.(1m) apart.
- **Don't** use any unapproved liquid or cleaning agent to clean the air conditioner.
- **Don't** attempt to repair the air conditioner by yourself. Incorrect repairs may cause fire or explosion. Contact a qualified service technician for all service requirement.
- **Don't** operate the air conditioner during a lightning storm. The power should be switched off to prevent danger or injury.
- **Don't** put hands or any objects into the air inlets or outlets. This may cause personal injury or damage to the unit.
- **Don't** block air inlet or air outlet. Otherwise, the cooling or heating capacity will be diminished, or cause the system to stop operating.

 **WARNING** 

- **This** appliance is not intended for use by persons (including children) with reduced physical, sensory or mental capabilities, or lack of experience and knowledge, unless they have been given supervision or instruction concerning use of the appliance by a person responsible for their safety.
- **Children** should be supervised to ensure that they do not play with the appliance.
- **Please** mount the system on a secure surface to prevent the unit from falling and causing injury or damage.
- **The** appliance shall be installed in accordance with national wiring regulations.
- **If** the supply cord is damaged, it must be replaced by the manufacturer, its service agent or similarly qualified persons in order to avoid a hazard.
- **Contact** a qualified service technician for all service requirements.
- **The** air conditioner must be grounded. Incomplete grounding may result in electric shocks.
- **Make sure** that the system has its own dedicated electrical circuit and that all electrical work is conducted by an individual that is certified or licensed to do such work in the state or region in which the insulation is taking place.
- **Ensure** the following objects are not under the indoor unit: Microwaves, ovens and other hot objects. Computers and other high electrostatic appliances. Electrical sockets. Items susceptible to water damage.
- **The** piping between indoor and outdoor unit shall not be reused, unless they can be properly flushed and re-flared.
- **The** specifications for electrical requirements are listed on the data plate of the unit.

 **WARNING** 

- **Always** switch off the device and cut the power supply when the unit is not in use for long time so as to ensure safety.
- **Always** switch off the device and cut the power supply before performing any maintenance or cleaning. Otherwise, it may cause electric shock or damage.
- **WARNING RISK OF ELECTRIC SHOCK. CAN CAUSE INJURY OR DEATH:** System contains oversize protective earthing (grounding) terminal which shall be properly connected.
- **WARNING RISK OF ELECTRIC SHOCK. CAN CAUSE INJURY OR DEATH:** System contains two independent protective earthing (grounding) terminals which both shall be properly connected and secured.

# Safety Precautions

## ⚠ WARNING



**This product contains fluorinated greenhouse gases.**

- **Refrigerant** leakage will contribute to climate change.
- **Never** tamper with the refrigerant system or attempt repair without proper training and compliance to local and national codes.
- **The** refrigerant in this system has a lower global warming potential (GWP) than a refrigerant with higher GWP, if leaked to the atmosphere. This appliance contains a refrigerant fluid with a GWP equal to [675]. This means that if 35 oz (1kg) of this refrigerant fluid would be leaked to the atmosphere, the impact on global warming would be [675] times higher than 35 oz (1kg) of CO<sub>2</sub>, over a period of 100 years.

## ⚠ CAUTION



- **Don't** operate the system with windows or doors open. Doing so will limit the system effectiveness.
- **Don't** stand on the top of the outdoor unit or place heavy objects on it. This could cause personal injuries or damage to the unit.
- **Don't** use the system for other purposes, such as drying clothes, preserving foods, etc.
- **Don't** apply the cold air to the body for a long time. It will deteriorate your physical conditions and cause health problems.

## ⚠ CAUTION



- **Appropriate** adjustments of the setting temperature can prevent the waste of electricity.
- **Use** an all-pole disconnection type breaker with at least 1/8 in. (3mm) between the contact point gaps that provide full disconnection under overvoltage category III.
- **If** your air conditioner is permanently connected to the fixed wiring, a residual current device (RCD) having rated residual operating current not exceeding 30 mA should be installed in the fixed wiring.
- **The** power supply circuit should have leakage protector and air switch of which the capacity should be more than 1.5 times of the maximum current.
- **Regarding** the installation of the air conditioners, please refer to the below paragraphs in this manual.

## E-Waste

- **Meaning** of crossed out wheeled dustbin:
- **Do not** dispose of electrical appliances as unsorted municipal waste, use separate collection facilities.
- **Contact** you local government for information regarding the collection systems available.
- **If** electrical appliances are disposed of in landfills or dumps, hazardous substances can leak into the groundwater and get into the food chain, damaging your health and well-being. When replacing old appliances with new ones, the retailer is legally obligated to take back your old appliance for disposals at least free of charge.



# Notices for Usage

## Operating Range

- Operating the unit outside the recommended temperature range may have an impact on the system performance. When the temperature is too high, the air conditioner may trip the circuit breaker causing the air conditioner to shut down. When the temperature is too low, the outdoor heat exchanger may generate excessive moisture, leading to water dripping from the unit.
- In long-term cooling or dehumidification with a relative humidity of above 80%, doors and windows should be closed to prevent the indoor unit from generating too much water and causing leaks.

Range	Indoor	Outdoor
Cooling	60.8~89.6°F (16~32°C)	-13~125.6°F (-25~52°C)
Heating	50~89.6°F (10~32°C)	-13~75.2°F (-25~24°C)

## Notes for Heating

- The fan of the indoor unit will not start immediately when the heating cycle has started. The unit will warm up and then start blowing air to avoid blowing out cool air.
- When it is cold and wet outside, the outdoor unit will develop frost over the heat exchanger which over time will cause the system to start the defrost function.
- During defrost, the air conditioner will stop heating for about 5-12 minutes.
- Vapor may come out from the outdoor unit during defrost. This is not a malfunction, but a result of fast defrost.
- Heating will resume after defrost is complete.

## Notes for Turning Off

- When the air conditioner is turned off, the main controller will automatically decide whether to stop immediately or after running for dozens of seconds with lower frequency and lower air speed.

# Notices for Installation

## Important Notices

- This unit must be installed by a certified contractor to avoid:  
Damage to the unit  
Refrigerant leaking in the atmosphere  
Electrical shock  
Burns from refrigerant  
Other serious injuries including death
- Leak test must be made after installation.
- To move and install air conditioner to another place, please contact our local authorized contractor.
- The range of external static pressures at which the appliance was tested:  
09K/12K: 25Pa(0-50Pa);  
18K/24K: 25Pa(0-80Pa).

## Installation Environment Inspections

- Check nameplate of outdoor machine to make sure whether the refrigerant is R32.
- Check the floor space of the room. The space shall not be less than usable space in the specification.
- The outdoor unit shall be installed at a well-ventilated place.
- Check the surrounding environment of installation site: R32 shall not be installed in the enclosed reserved space of a building.
- When using electric drill to make holes in the wall, check first whether there is pre-buried pipeline for water, electricity and gas. It is suggested to use the reserved hole in the roof of the wall.

## Unpacking Inspections

- Open the box and check air conditioner in area with good ventilation and without ignition source.
- Note: Operators are required to wear anti-static devices.
- It is necessary to check whether there is refrigerant leakage before opening the box of outdoor machine; stop installing the air conditioner if leakage is found.

- Fire prevention equipment should be prepared before starting the installation.
- Then check the refrigerant pipeline to see if there is any damage or leaks.

## Safety Principles for Installing Air Conditioner

- Fire prevention device shall be prepared before installation.
- Keep installing site ventilated.(open the door and window)
- Do not allow any ignition sources, smoking, or phone calls in areas where R32 refrigerant is present.
- Anti-static precautions in necessary for installing air conditioner, e.g. wear pure cotton clothes and gloves.
- Ensure the leak detector is operational during the installation.
- If R32 refrigerant leakage occurs during the installation, you shall immediately detect the concentration in indoor environment until it reaches a safe level.
- If refrigerant leakage affects the performance of the air conditioner, please immediately stop the operation, and the air conditioner must be vacuumed firstly and be returned to the maintenance station for processing.
- Keep electric appliance, power switch, plug, socket, high temperature heat source and high static away from the area underneath sidelines of the indoor unit.
- The air conditioner shall be installed in an accessible location for installation and maintenance, without obstacles that may block air inlets or outlets of indoor /outdoor units. It shall be kept away from heat source, inflammable or explosive conditions as well.
- When installing or repairing the air conditioner and the connecting line is not long enough, the entire connecting line shall be replaced with the connecting line of the original specification; extension is not allowed.
- When installing an R32 HVAC system, it's crucial to ensure that the installation site meets specific safety requirements due to the flammable nature of R32 refrigerant.

# Notices for Installation

## Requirements for Installation Position

- Avoid places of flammable or explosive gas leakage or where there is poor ventilation.
- Avoid places subject to strong electric/magnetic fields like microwaves and fluorescent lights.
- Avoid places like subject to noise and resonance like walls above a sleeping area.
- Avoid severe natural conditions (e.g. strong wind, direct sunshine or high temperature heat sources).
- Avoid places within the reach of children.
- Shorten the connection between the indoor and outdoor units as much as possible for best performance.
- Select a location where it is easy to perform service and repair.
- The outdoor unit shall not be installed in any way that could occupy an aisle, stairway, exit, fire escape, catwalk or any other public area.
- The outdoor unit shall be installed as far as possible from the doors and windows of the neighbors as well as plants.

## Requirements of the Mounting Structure

- The mounting rack must meet the relevant national or industrial standards
- It is recommended that the mounting rack and its load carry surface shall be able to withstand 4 times or above the weight of the unit.
- The mounting rack of the outdoor unit shall be fastened with expansion bolts or as recommended by the manufacturer.
- Ensure the secure installation regardless of what type of wall on which it is installed, to prevent potential dropping that could cause damage or injury.

## Requirements for Operations at Raised Height

- When carrying out installation at 6-9/16ft. (2m) or higher above the base level, safety belts must be worn and ropes of sufficient strength must be securely fastened to the outdoor unit to prevent falling that could cause personal injury or death as well as property loss.

## Grounding Requirements

- Be sure to properly ground the unit. Follow all local and national codes as applicable.
- Do not connect the grounding wire to a gas pipe, water pipe, lightning rod, telephone line, or a circuit poorly grounded to the earth.
- The grounding wire is specially designed and shall not be used for other purpose, nor shall it be fastened with a common tapping screw.
- Ensure that all electrical connects are securely fastened and connected to the correct terminals.
- Local and national electrical codes must be utilized.





## Others



- The connection method of the air conditioner and the power cable and the interconnection method of each independent element shall be subject to the wiring diagram affixed to the machine.
- The model and rating value of the fuse should match the information printed on the silkscreen of the corresponding controller or the fuse sleeve. This ensures that the fuse is correctly rated for the specific application, providing proper protection and functionality.

# Installation Diagram

## Accessories

The air conditioning system comes with the following accessories. Use all of the installation parts and accessories to install the air conditioner. Improper installation may result in water leakage, electrical shock and fire, or equipment failure.

Installation Fittings		
Name	Shape	Quantity
Installation and owner's manual(this book)		1
Metal clamp		2
Drain hose		1
Clamp		8
Insulation for fitting (for liquid pipe)	 Thin	1

Name	Shape	Quantity
Insulation for fitting (for gas pipe)	 Thick	1
Screw for duct flanges		2
Sealing pad		1

# Before Operation Check List

**For the following items, take special care during construction and check after installation is finished.**

## 1. Items to be checked after completion of work

Items to be checked	If not properly done, what is likely to occur.	Check
Are the indoor and outdoor unit fixed firmly?	The units may drop, vibrate or make noise.	
Was the installation of the outdoor unit completed?	The unit may malfunction or the components burn out.	
Is the gas leak test finished?	No cooling or heating.	
Is the unit fully insulated? (Refrigerant piping, drain piping, and duct)	Condensate water may drip.	
Dose drainage flow smoothly?	Condensate water may drip.	
Does the power supply voltage conform to the indication on the name plate?	The unit may malfunction or the components burn out.	
Are wiring and piping correct?	The unit may malfunction or the components burn out.	
Is the air conditioner or heat pump properly grounded?	Dangerous in case of current leakage.	
Is wiring size according to specifications?	The unit may malfunction or the components burn out.	
Is something blocking the air outlet or inlet of either the indoor or outdoor units?	No cooling or heating.	
Did you set the external static pressure?	No cooling or heating.	
Are refrigerant piping length and additional refrigerant charge noted down?	The refrigerant charge in the system is not clear.	
Did you check that no wiring connection screws were loose?	Electric shock or fire.	

## 2. Items to be checked at the time of delivery

Items to be checked	Check
Are you sure the control box lid, air filter, air inlet grille, and air outlet grille are mounted?	
Did you explain about operations while showing the operation manual to your customer?	
Did you deliver the operation manual along with the installation manual to the customer?	
Did you explain the customer the handling and cleaning methods of the field supplies (e.g., the air filter, air inlet grilles, and air outlet grille)?	
Did you deliver instruction manual, if any, for the field supplies to the customer?	

## 3. Points for explanation about operations

The items with WARNING and CAUTION marks in the operation manual are the items pertaining to possibilities for bodily injury and material damage in addition to the general usage of the product. Accordingly, it is necessary that you make a full explanation about the described contents and also ask your customers to read the operation manual.

### Note to Installer

- Be sure to instruct customers how to properly operate the unit (especially cleaning filters, operating different functions, and adjusting the temperature) by having them carry out operations themselves while looking at the manual.

# Installation of the Indoor Unit

## Selecting Installation Site

For convenience of maintenance , please reserve a service port. Ensure the following conditions are satisfied and confirm the position with the customer.

- The position must allow the air to not be obstructed
- The distance away from the wall and obstacles is shown in the drawing below.
- The installation site should be convenient for water draining (See "Drain Piping Work" for details).
- For ducted type indoor unit , the suspension site should be able to support the weight 4 times Greater than the indoor unit. There should be no increase in noise and vibration. If it needs to be reinforced , the installation should be carried on after reinforcement (if reinforcement is weak ,the indoor unit will fall and cause damage) .
- The indoor unit must be away from sources of heat or steam and way from entrances.
- The indoor unit position is near the power source (special line).
- The indoor unit position must allow for easy connection to the outdoor unit.
- The indoor unit position should keep away from direct sunlight and moisture.
- The height inside the ceiling should reach the drainage requirements to ensure the installation of indoor unit.
- Unit cannot be installed in rooms with poor ventilation and high moisture levels.
- In the inlet and outlet of indoor unit , protective barriers should be installed to prevent finger from inserting or contacting the fan with highspeed and metal fin.

**Must carry out a full jobsite inspection before installation.**

**Look for the following:**

- In restaurants and kitchens, ensure the kitchen extract fan and hood can effectively exhaust oil, steam, flour, and other by-products. Position the indoor unit away from cooking areas to avoid contamination. Regularly clean and maintain the indoor fan, heat exchanger, and drain pump. Use high-quality filters to trap fine particles and ensure all ducts and connections are sealed and insulated. These measures will help maintain performance and reduce the risk of failures.

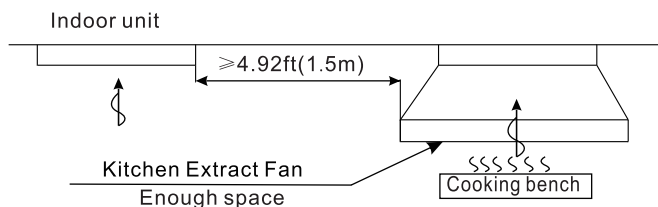

- The capacity of the kitchen extract fan and extract hood should be great enough to ensure that the oil, steam, flour and other cooking products will be exhausted through it and not attracted into the air conditioner. The indoor unit should be far enough away from the cooking and food preparation equipment to ensure that cooking products are not attracted into the unit.
- When installing the unit in a factory, ensure it is situated in a place where it will not be contaminated by oil, powder, iron filings or dust.
- Do not install near potential sources of combustible gas.
- Do not install where acidic or corrosive gases are present.
- Use suspension bolts to install the indoor unit. Check that the place of installation withstands the weight of the indoor unit. Secure the suspension bolts with proper beams if necessary.

## The Location of Hoisting Bolt

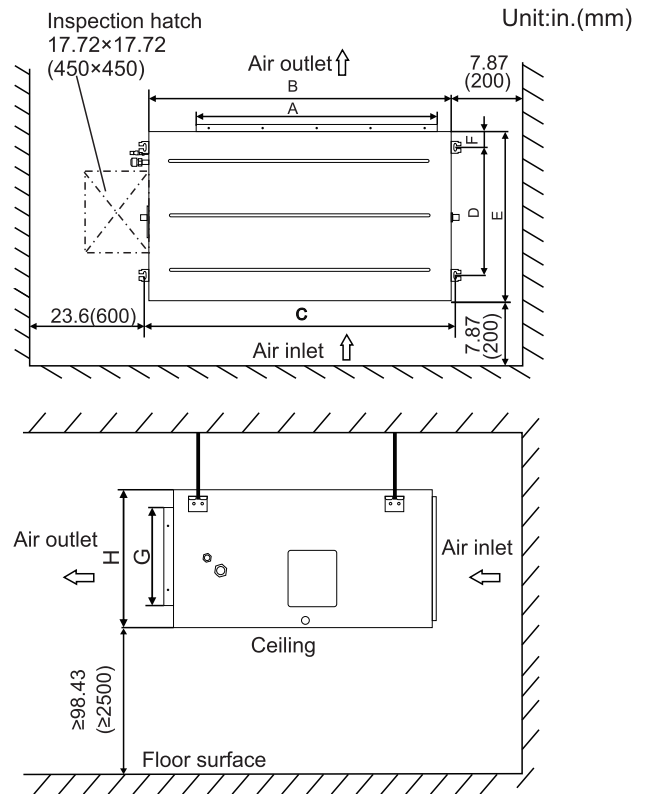

Type	A	B	C	D	E	F	G	H
09K/12K	20.4 (517)	27.6 (700)	29.3 (744)	13.8 (350)	17.7 (450)	1.97 (50)	5.71 (145)	7.80 (198)
18K	20.2 (512)	27.6 (700)	29.1 (739)	23.6 (600)	27.6 (700)	2.0 (52)	6.97 (177)	9.6 (245)
24K	32.0 (812)	39.4 (1000)	40.9 (1039)					

- Mount the canvas ducts to the air outlet and inlet so that the vibration of the air conditioner will not be transmitted to the duct or ceiling. Apply a sound-absorbing material (insulation material) to the inner wall of the duct and vibration insulation rubber to the suspension bolts.

## Open Installation Holes

- If the ceiling already exists. Open the installation holes on the ceiling. Lay the refrigerant piping, drain piping, power line, transmission wiring, and remote controller wiring for the piping and wiring connection port of the unit.

In the case of the installation of a wireless remote controller, refer to the installation manual provided with the wireless remote controller.

- The ceiling framework may need reinforcement in order to keep the ceiling horizontal and prevent the vibration of the ceiling after the installation holes are opened. For details, consult your construction or interior contractor.

# Installation of the Indoor Unit

## Install The Suspension Bolts.

Make sure that the suspension bolts are M10 or the equivalent in size.

- Use hole-in anchors if the suspension bolts already exist; otherwise use embedded inserts and embedded foundation bolts so that they will withstand the weight of the unit. Adjust the distance to the ceiling surface in advance.

(Installation example)

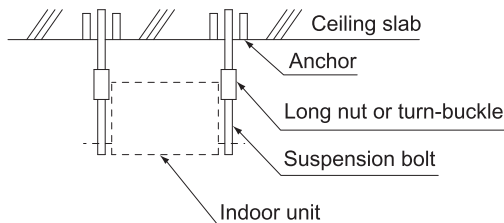

**Note: All the above parts are field supplied.**

## Temporarily Install The Indoor Unit

- Connect the hangers to the suspension bolts. Be sure to use and tighten the nut and washer for hanger for each hanger from both upper and lower sides of the hanger.

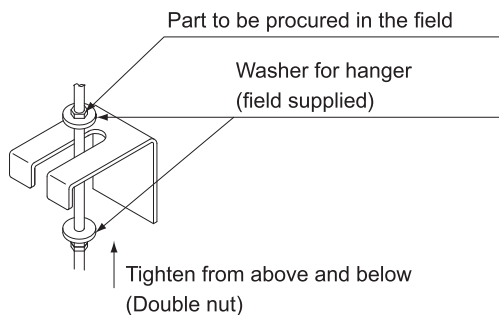

## INDOOR UNIT INSTALLATION

- Keep the air outlet covered with a protective sheet to prevent weld splatter and other foreign materials from entering the indoor unit, and damaging the resin drain pan. Water leakage may occur if holes or cracks are generated in the resin drain pan.
- Make adjustments so that the unit will be in the right position.
- Check the level of the unit.
- Tighten the upper side nuts, and securely fix the unit.

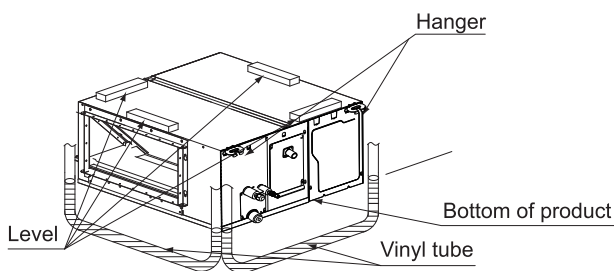

- Use the level and check that the unit is installed horizontally. (4-directions)
- In the case of using a vinyl tube (filled with water) in place of the level, align the bottom of the unit to the water surface at both edges of the vinyl tube to make levelness adjustment. If the unit is installed at a slant with the drain pipe side set high, in particular, the float switch will not operate normally and water leakage may result.

## Piping Works and Flaring Techniques

- Do not use contaminated or damaged copper tubing. If the evaporator, condenser, or any piping has been open and exposed to the atmosphere the system must be evacuated below 500 microns. Do not remove plastic plugs or brass nuts from piping connections until the connections are ready to be made.
- If any brazing work is required, ensure that a nitrogen gas purge is utilized to prevent soot formation on the inside wall of copper tubing. Failure to do so may cause damage to the unit and void warranty.
- Cut the pipe as straight as possible (See Fig. 1). Make sure to use a deburring tool to remove any burrs. Hold the pipe with opening facing down to prevent metal chips from entering the pipe (See Fig. 2). (use caution to not allow shavings to fall inside the piping)
- This will avoid unevenness on the flare faces which will cause gas leak.
- Insert the flare nuts, mounted on the connection parts of both the indoor unit and outdoor unit, into the copper pipes.
- The exact length of pipe protruding from the top surface of the swaging block is determined by the flaring tool. (See Fig. 3)
- Fix the pipe firmly on the swaging block. Match the centers of both the swaging block and the flaring punch, then tighten the flaring punch fully.
- The refrigerant pipe connection are insulated by closed cell polyurethane.

Fig. 1

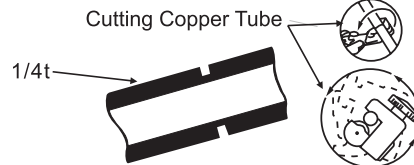

Fig. 2

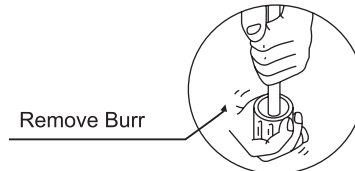
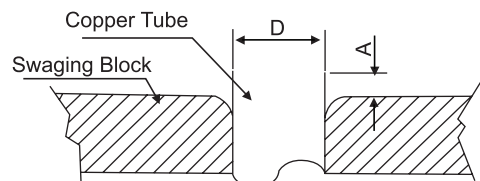

Fig. 3



Ø Tube, D	A(Inch/mm)		
	Inch	mm	Imperial (Wing-nut Type) Rigid (Clutch Type)
1/4		6.35	0.051" (1.3) 0.028" (0.7)
3/8		9.52	0.063" (1.6) 0.039" (1.0)
1/2		12.70	0.075" (1.9) 0.051" (1.3)
5/8		15.88	0.087" (2.2) 0.067" (1.7)
3/4		19.05	0.098" (2.5) 0.079" (2.0)

# Installation of the Indoor Unit

## Requirement of Brazing the Pipe

- Make sure that there is no moisture inside the pipe.
- Make sure that there are no foreign materials and impurities in the pipe. Make sure that there are no leaks.
- Be sure to follow the instruction when brazing the pipe.

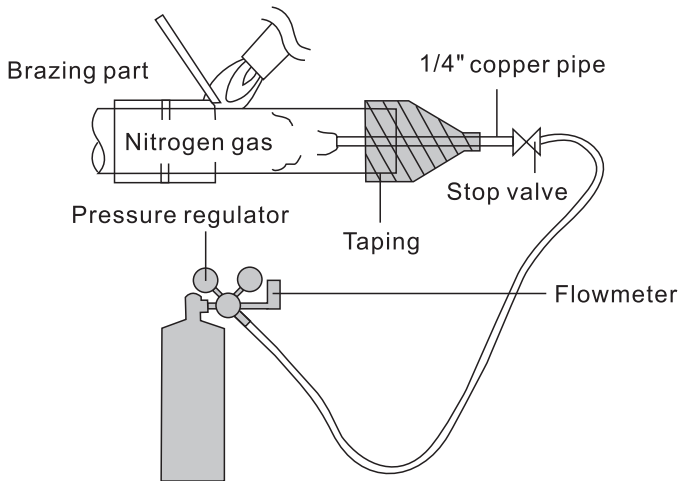

## The use of Nitrogen gas

- Use Nitrogen gas when brazing the pipes as shown in the picture. If you do not use Nitrogen gas when brazing the pipes, oxide may form inside the pipe. It can cause damage to the compressor and valves, may also cause refrigerant restrictions and poor performance.
- Adjust the flow rate of the Nitrogen gas with a pressure regulator to maintain 0.05m<sup>3</sup>/h or less.

### CAUTION

Do not use antioxidant when brazing piping. It may result in malfunction of components and clogging of piping due to residue.

## Install The Connection Pipe

### Connect the pipe to the unit

Align the center of the piping and tighten the flare nut sufficiently with fingers.

Finally, tighten the flare nut with torque wrench until the wrench clicks.

When tightening the flare nut with the torque wrench, ensure that the tightening direction follows the arrow indicated on the wrench.

The refrigerant pipe connection are insulated by closed cell polyurethane.

Tightening torque table

The size of pipe, in.(mm)	Torque, ft-lb(N·m)
Ø1/4 (Ø6.35)	11.0-18.4 (15-25)
Ø3/8 (Ø9.52)	25.8-29.5 (35-40)
Ø1/2 (Ø12.7)	33.2-44.3 (45-60)
Ø5/8 (Ø15.88)	53.9-57.6 (73-78)
Ø3/4 (Ø19.05)	55.3-59.0 (75-80)

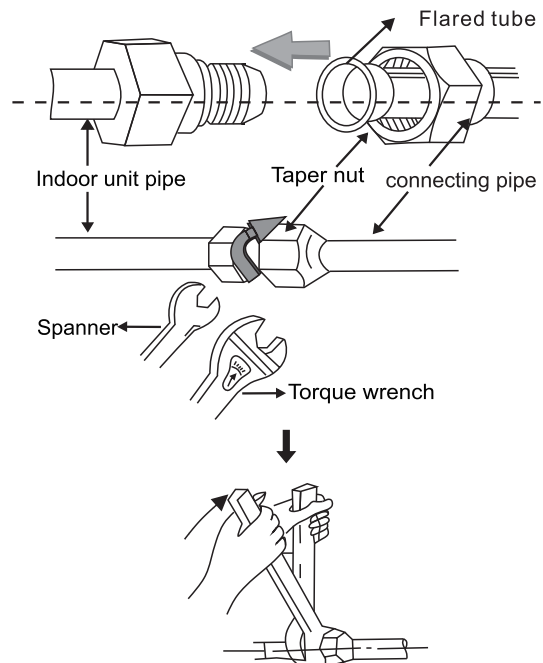

# Installation of the Indoor Unit

## Installation of tubing

- On completion of installation work, check that there is no gas leakage.
- Refer to the following illustration and be sure to perform thermal insulation work on the piping joints after gas leakage checks.

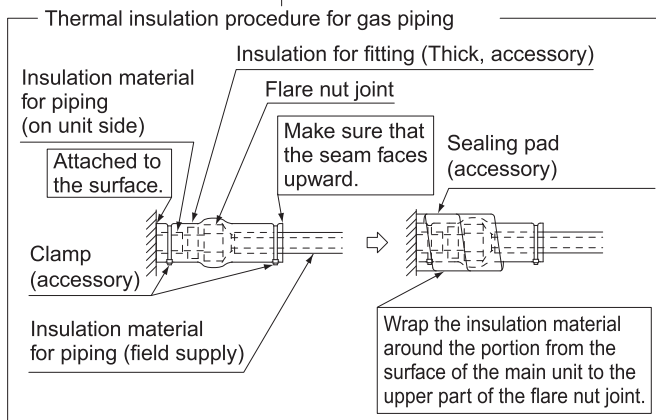
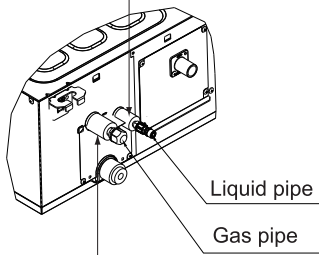
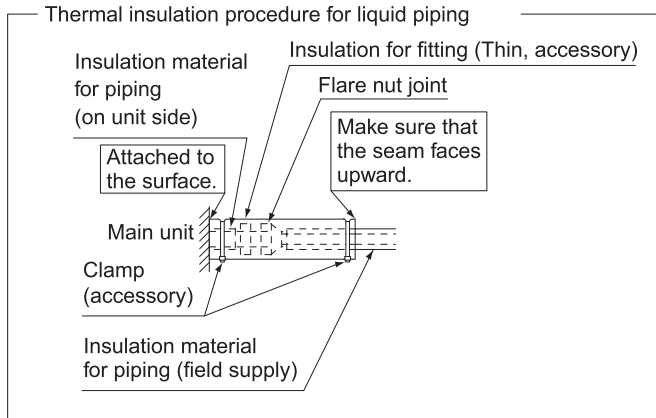

- Use the insulation for fitting provided to the liquid piping and gas piping, respectively, and conduct thermal insulation work. (Tighten both edges of the insulation for fitting for each joint with the clamp.)
- Make sure that the joint of the insulation for fitting for the joint on the liquid piping and gas piping side faces upward.
- Wrap the middle sealing material around the insulation for fitting for the joint (flare nut part).

### CAUTION

- Be sure to perform the thermal insulation of the local piping up to the piping joint. If the piping is exposed, dew condensation may result. Furthermore, a burn may be caused if a human body comes in contact with the piping.

## Drain Piping Work

### 1. Conduct drain piping work Check that the piping

- Make sure that the diameter of the piping excluding the rising part is the same as or larger than the diameter of the connecting pipe (vinyl chloride pipe with an outer diameter of 1.26in. (32 mm) and a nominal inner diameter of 1 in.(25 mm)).
- Make sure that the piping is short enough with a downward slope of at least 1/100 and that there is no air bank formed. No drain trap is required.

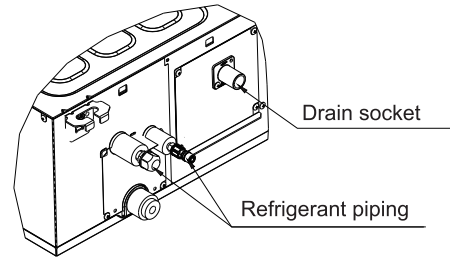

### CAUTION

- The drain piping will be clogged with water and water leakage may result if the water is accumulated in the drain piping.

- Conduct drain-up piping work if the gradient is insufficient.
- Attach a support bracket at 3.3 to 4.9 ft (1 to 1.5 m) intervals for the prevention of piping deflection.

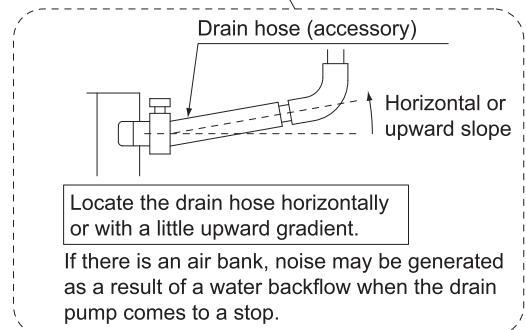
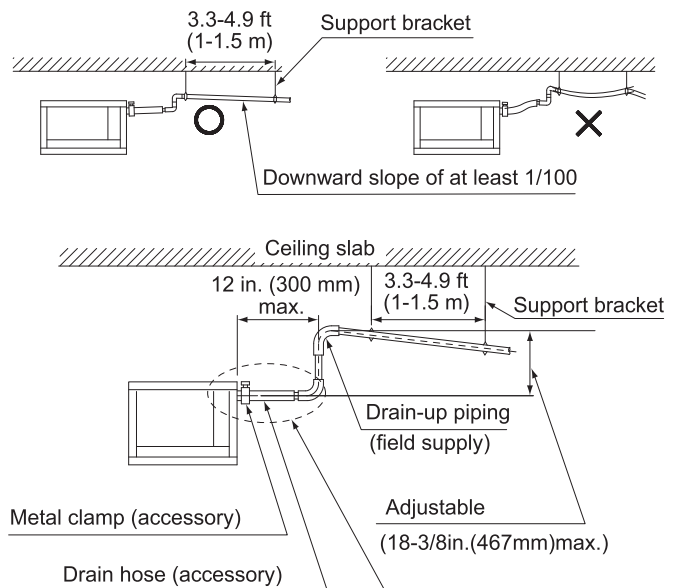

# Installation of the Indoor Unit

• The drainage pipes should have good insulation measures. The specific steps are as follows:

- a: The drainage hoses should be tightly clamped with the inner water outlet and the drainage pipe respectively, then fix with a hoop, as shown in Fig.1.
- b: Wrap the heat insulation cotton on the drain insulation pipe and the hoop, as shown in Fig. 2 .
- c: Tighten the sponge with a plastic tie, as shown in Fig.3 .

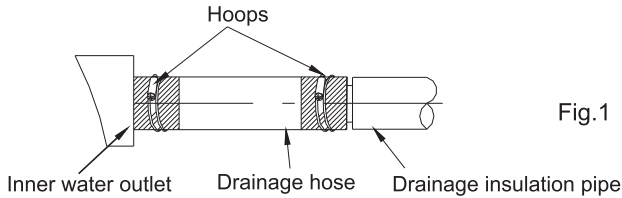

Fig.1

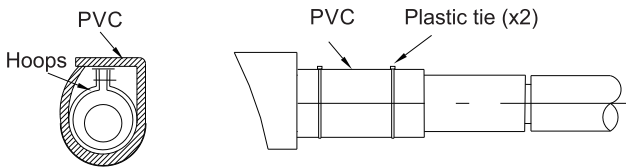

Fig.2

Fig.3

**NOTE:**

**Be sure to follow the instructions as below.**

- **Do not connect the drain piping directly to a sewer that smells of ammonia.**  
*The ammonia in the sewer may reach through the drain piping and corrode the heat exchanger of the indoor unit.*
- **Do not bend or twist the provided drain hose in order not to impose excessive force on the hose. (Doing so may result in water leakage.)**
- **Take the procedure shown in the following illustration to perform concentrated drain piping.**

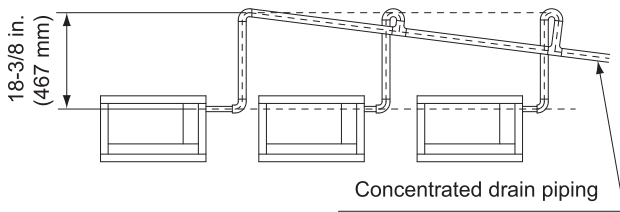

Concentrated drain piping

**CAUTION**

- Maintain a downward slope of at least 1/100 so that no air bank will be formed.  
The drain piping will be clogged with water and water leakage may result if the water is accumulated in the drain piping.

**2.Check that drainage flows smoothly on completion of the installation of the piping.**

**[Before electrical work]**

- The connection method of the air conditioner and the power cable and the interconnection method of each independent element shall be subject to the wiring diagram affixed to the machine.

**CAUTION**

- Also need to clarify licensed electrician is only responsible for wiring from breaker panel to disconnect.

- 1). Remove the control box cover, and connect the single phase electric wires to terminals L1 and L2 of the terminal block and the ground wiring to the ground terminal.

**CAUTION**

- In order not to impose tension on the wire connections, perform clamping securely with the provided clamp specified. Connecting power supply, ground, remote controller, and transmission wiring.

- 2). Check that the control box cover is closed before turning the air conditioner ON.
- 3). Provide approximately 1/4 gal (1L ) of water gradually into the drain pan through the water inlet on the bottom of the drain socket or the outlet. Make sure that the water is not spilled onto the drain pump.
- 4). The drain pump will operate with the power turned ON. Check that the pump drains water smoothly. (The drain pump will stop automatically in 10 minutes.)  
The drainage can be checked with the water level change in the drain pan through the water inlet.

**CAUTION**

- **Do not touch the drain pump.**  
Otherwise, an electric shock may be received.
- **Do not impose external force on the float switch.**  
Otherwise, a failure may result.

- 5). On completion of the drainage check, shut off the power supply and disconnect the power supply wiring.
- 6). Put the control box cover to the original position.

**[After electrical work]**

- After completion of provide approximately 1/4 gal (1L ) of water gradually into the drain pan through the water inlet on the bottom of the drain socket, and check that the water is drained while the air conditioner is in cooling operation according. Make sure that the water is not spilled onto the electric parts of the drain pump and others.

# Installation of the Indoor Unit

**3. Be sure to conduct thermal insulation work on the following portions, or otherwise water leakage may occur as a result of dew condensation.**

- Drain piping indoors
- Drain socket

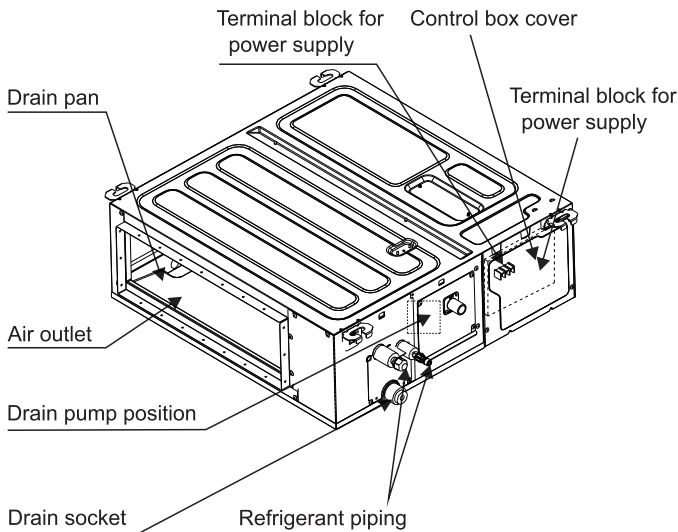

• On completion of the drainage check, refer to the following illustration, and use the provided large sealing pad and insulate the metal clamp and drain hose.

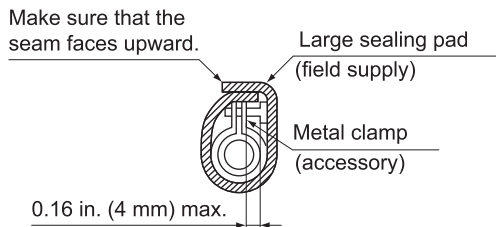

## DUCT WORK

**Pay utmost attention to the following items and conduct duct work.**

- Check that the duct will not be in excess of the setting range of external static pressure for the unit. (Refer to Engineering Data for the setting range. Each model has each setting range of external static pressure.)
- Attach a canvas duct each to the air outlet and air inlet so that the vibration of the equipment will not be transmitted to the duct or ceiling.  
Use a sound-absorbing material (insulation material) for the lining of the duct and apply vibration insulation rubber to the suspension bolts.
- At the time of duct welding, protect the opening of the duct so that the sputter will not come in contact with the drain pan or the filter.
- If the metal duct pass through a metal lath, wire lath, or metal plate of a wooden structure, separate the duct and wall electrically.
- Be sure to insulate the duct for the prevention of dew condensation. (Material: Glass wool or styrene foam; Thickness: 1in. (25 mm))

- Be sure to attach a field supplied air filter to the air inlet of the unit or field supplied inlet in the air passage on the air suction side. (Be sure to select an air filter with a duct collection efficiency of 50 weight percent.)
- Explain the operation and cleaning method of the field supplied components (i.e., the air filter, air inlet grille, and air outlet grille) to the customer.
- Locate the air outlet grille on the indoor side for the prevention of drafts in a position where indirect contact with people.
- The air conditioner incorporates a function to adjust the fan to rated speed automatically.  
Therefore, do not use booster fans midway in the duct.

### Connection method of ducts on air inlet and outlet sides.

- Connect the field supplied duct in alignment with the inner side of the flange.
- Connect the flange and unit with the flange connection screw.
- Wrap aluminum tape around the flange and duct joint in order to prevent air leakage.

### CAUTION

Connect the flange to the unit with the flange connection screw even in case of no duct connection.

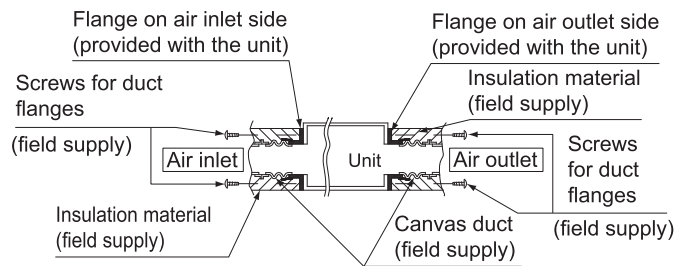

# Electric Wiring Work

## Electrical Safety Requirements

- Be sure to use the correct rated voltage for the air conditioner and a dedicated circuit for the power supply,
- Follow local and national codes for the correct power cable AWG.
- The operating range is 90%-110% of the local rated voltage. Insufficient power supply causes malfunction, electrical shock, or fire. If the voltage instability occurs, install the voltage regulator.
- The minimum clearance between the air conditioner and the combustibles is 49.21 in or greater.
- Use the correct wire size and type for connecting the indoor unit to the outdoor unit.
- The size of the interconnection cord, power cable, fuse, and switch needed is determined by the maximum current of unit.
- The maximum current is indicated on the nameplate located on the side panel of the unit. Refer to this nameplate to choose the right wire size, breaker, or switch.

## WARNING

- All electrical works must be carried out & checked by a qualified electrician and must adhere to the IET regulations, local and national legislation and industry best practice. The system must have its own independent power supply.
- Do not attempt any electrical works yourself.
- An Earth Leakage Protector, Power Switch and Circuit Breaker or Fuse must be installed in the dedicated power supply or there is the risk of electric shock.
- The grounding must be reliable. If grounding is not correct, it may lead to electric shock.
- All power cables should be properly secured with cable ties so that external forces can not disconnect the wired from the terminals. Improper connections or insecure fastening can cause electric shocks or fire.
- Use an all-pole disconnection type breaker with at least 1/8 in (3mm) between the contact point gaps that provide full disconnection under overvoltage category III.

## CAUTION

- Do not connect the earth cable to gas or water pipes, telephone lines, lightning rods or the earth cables of other products.
- Once the indoor and outdoor unit have been powered on, do not cut off power supply within 1 minute, otherwise abnormal operation will be caused.
- Please connect the power cord and interconnecting cable according to the wiring diagram.
- Connect the wire firmly to the terminal block using crimps and secure in order to prevent external forces pulling on the wire causing risk of fire or electric shock.
- After the electrical connection is completed, all wires should be prevented from touching other parts such as tubing, compressor etc.

## NOTE

- The definition of power cord is the power supply cable from the isolating switch attached to the dedicated power supply to the indoor unit or outdoor unit. Interconnecting cable for the indoor and outdoor unit is the power cable that connects indoor unit and outdoor unit.
- Above-mentioned definitions are the specifications of power supply, power cord and interconnecting cable of indoor unit and outdoor unit of all different types of air conditioners.
- To avoid voltage drops, when the cross sectional area of a power cable core reaches the minimum size, and the power cord is lengthened, you should choose another bigger power cable size.

## Connection Wire

- The indoor units in the same system can be connected to the power supply from one branch switch. However, selection of branch switch, branch over current circuit breaker and wiring size must be according to applicable legislation.
- For connection to the terminal block, use a ring type crimp style terminals with insulation sleeve or insulate the wirings properly.

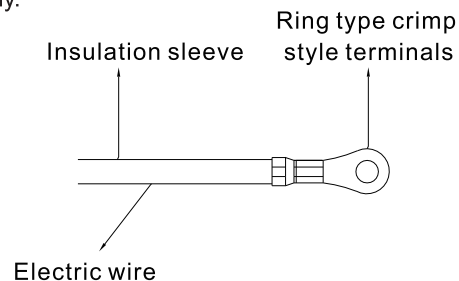

Connect wires of the same gauge to both sides.

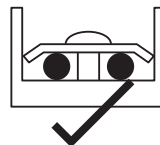

Do not connect wires of the same gauge to one side.

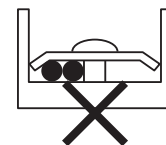

Do not connect wires of different gauges.



**If the wiring gets too hot due to loose power-supply wiring, use the following precautions:**

- For wiring, use the designated power supply wiring and connect firmly, then secure to prevent outside pressure being exerted on the terminal board.
- Use the correct screwdriver for tightening the terminal screws. If the blade of screwdriver is too small, the head of the screw might be damaged, and the screw will not be properly tightened.
- If the terminal screws are tightened too hard, screws might be damaged.

# Electric Wiring Work

## Routing wiring

Remove the control box cover as shown below and connect each wire.

- Remove the control box cover.

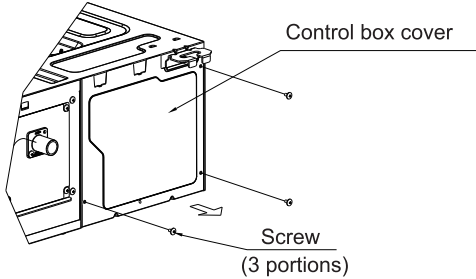

- Lay the wires in the control box through the wire inlet on the side of the control box.

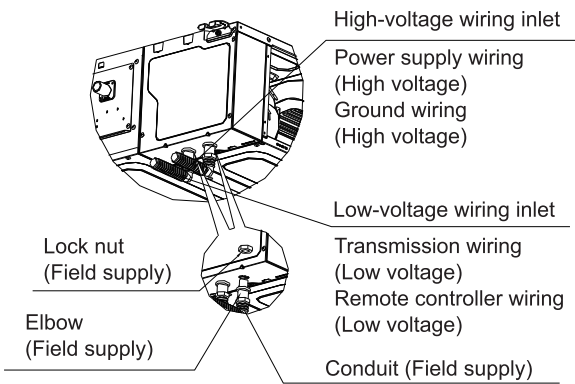

### CAUTION

- Do not lay the remote controller wiring or transmission wiring along with the power supply wiring or other electric wiring in the same route. Separate the remote controller wiring and transmission wiring at least 2 in. (50 mm) from the power supply wiring or other electric wiring, or otherwise malfunctions or failures may be caused by external electric noise that may interfere with the remote controller wiring and transmission wiring.
- For the installation and wiring of the remote controller, refer to the remote controller installation manual provided with the remote controller.
- For power supply wiring, refer to the wiring diagram as well.
- Be sure to connect the remote controller wiring and transmission wiring correctly to the right terminal block.

- Follow the instructions below, and lay the wires in the control box.

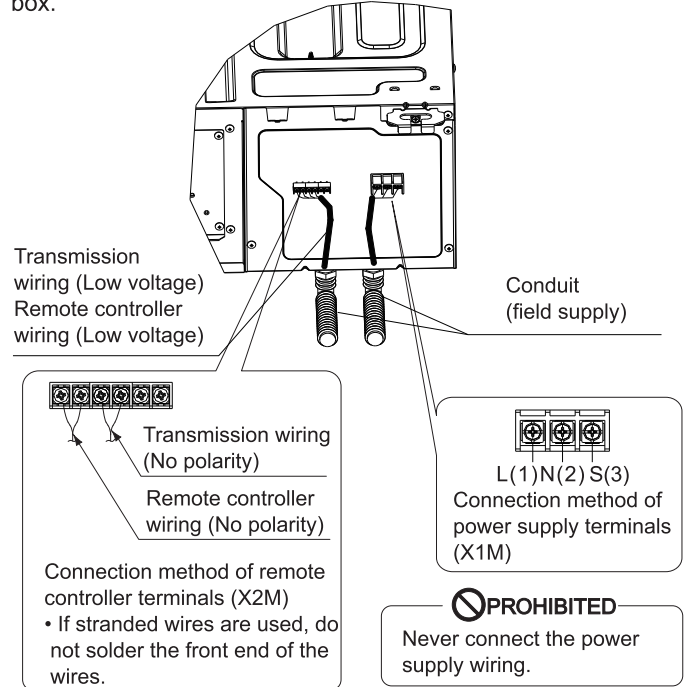

- Put the control box cover, and wrap the wire sealing material (Small) around the conduit so as to block the wire through holes.

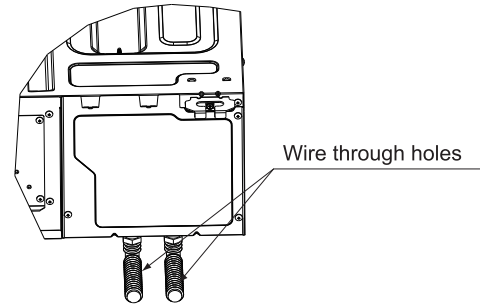

### CAUTION

After all the wiring connections are done, fill in any gaps in the through holes with putty or insulation (procured locally) to prevent small animals and insects from entering the unit from outside. (If any does get in, they could cause short circuits in the control box.)

- For protection from uninsulated live parts, thread the high and low voltage wirings through each of the included insulating tube and secure it with the included clamp separately.

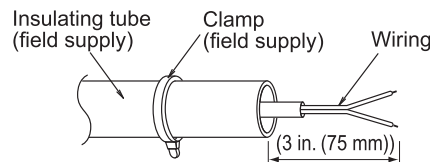

### When using the insulating tube

- Cut off the insulation tube at needed length.

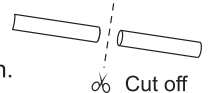

### CAUTION

**Trim and lay the wiring neatly and attach the control box cover securely.**

An electric shock or fire may result if the control box cover catches any wiring or the wires push up the cover.

# Electric Wiring Work

## Installation of magnetic ring

### A magnetic ring inside the accessory bag:

① If the model is equipped with a wired controller, the communication line on the wired controller side must be wound with a magnetic ring for 5 turns, and the indoor power lines L and N must be wound with another magnetic ring for 3 turns.

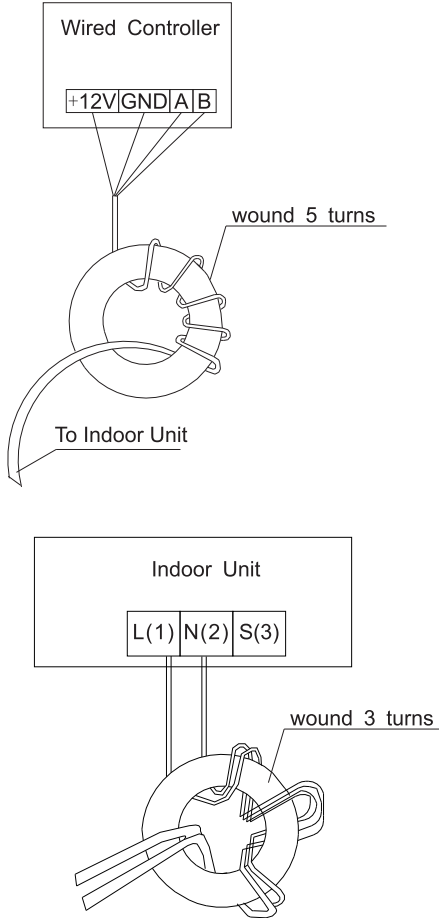

② If the model is not equipped with a wired controller, the indoor power lines L and N must be wound 3 turns with this magnetic ring.

### Two magnetic rings inside the accessory bag:

① If the model is equipped with a wired controller, the communication line on the wired controller side must be wound with a magnetic ring for 5 turns, and the indoor power lines L and N must be wound with another magnetic ring for 3 turns, and the ground wire must be circled by another magnetic ring for 3 turns.

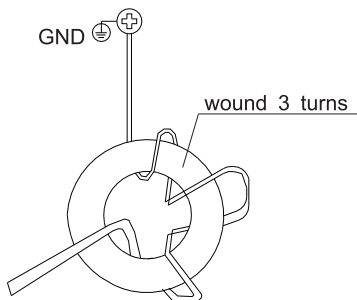

② If the model is not equipped with a wired controller, the indoor power lines L and N must be wound 3 turns with this magnetic ring, and the ground wire must be circled by another magnetic ring for 3 turns.

**Note: The communication line of the line controller must use shielded twisted pair cables.**

## Wiring Example

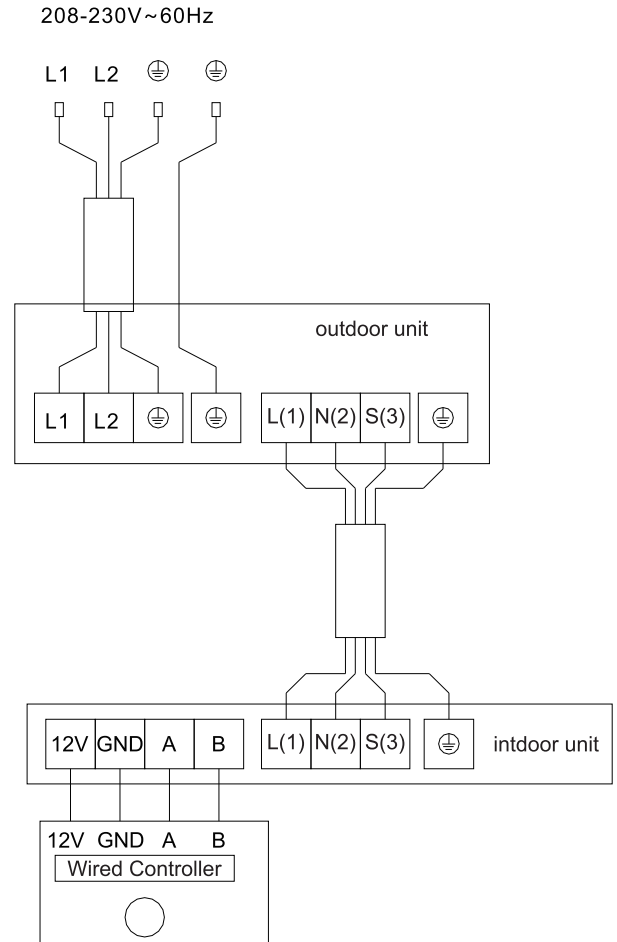

Model	Power connection line	Wired Controller line	fuse nominal value (controlling panel)	Certification Type
9K	18AWG	24AWG	5A	UL
12K				
18K				
24K				

# Testing and Inspection

## Check after Installation

### ● Electrical Safety Check

1. If the supply voltage is within tolerance.
2. If the indoor and outdoor units are properly wired.
3. If the grounding wire of the air conditioner is securely grounded.

### ● Installation Safety Check

1. If the unit is mounted properly and securely.
2. If the water drains smoothly from indoor unit to outdoor drain.
3. If the wiring and piping are correctly installed and free of leaks.
4. Check that no foreign matter or tools are left inside the unit.
5. Check the refrigerant pipeline and connections are properly insulated.

### ● Leak test of the refrigerant

Depending on the installation method, the following methods may be used to check for suspect leak, on areas such as the connections of the outdoor unit and the cores of the cut-off valves and t-valves:

1. Bubble method: Apply of spray a uniform layer of soap water over the suspected leak spot and observe carefully for bubble.
2. Instrument method: Checking for leak by pointing the probe of the leak detector according to the instruction to the suspect points of leak.

### **Note:**

***Make sure that the ventilation is good before checking.***

## Test Operation

### ● Test Operation preparation:

1. Verify that all piping and wiring is properly connected.
2. Confirm that the valve at the gas side and the liquid-side are fully open.
3. Verify that power is turned on to the unit.
4. Install batteries in the remote control.

### **Note:**

***Make sure that the ventilation is good before testing.***

### ● Test Operation method:

1. Turn on the power and push the ON/OFF switch button of the remote controller to start the air conditioner.
2. Select COOL or HEAT, adjust the SWING and other operation modes with the remote controller to verify proper operation.

### ● Attention:

1. For maintenance or scrap, please contact authorized service contractors.
2. Maintenance by unqualified person may cause injury or death.
3. Charge the air conditioner with R32 refrigerant, and maintain the air conditioner in strict accordance with manufacturer's requirements. The chapter is mainly focused on special maintenance requirements for appliance with R32 refrigerant.
4. Ask repairer to read after-sales technical service handbook for detailed information.

# Maintenance Notice

## **Attention :**

**For maintenance or scrap, please contact a authorized contractor.**

**Maintenance by unqualified person may cause injury or damage to the unit.**

**Charge air conditioner with R32 refrigerant only, and maintain the air conditioner in a strict accordance with the manufacturer's requirements.**

## **Qualification of Workers**

1. Special training is required to work on equipment with A2L refrigerants. Only rely on qualified contractors to install, service, and repair this system.

2. The maintenance and repair of the air conditioner must be conducted according to the method recommended by the manufacturer.

If other professionals are needed to help maintain and repair the equipment, it should be conducted under the supervision of individuals who have the qualification to repair AC equipped with flammable refrigerants.

## **Inspection of the Site**

Safety inspection must be conducted before maintaining equipment with R32 refrigerant to make sure the risk of fire is minimized.

Check whether the space is well ventilated and whether anti-static or fire prevention equipment is required.

While maintaining the refrigeration system, observe the following precautions before operating the system.

## **Operating Procedures**

### **1. General work area:**

All maintenance staff and others working in the local area shall be instructed on the nature of work being carried out. Work in confined spaces shall be avoided.

### **2. Checking for presence of refrigerant:**

The area shall be checked with an appropriate refrigerant detector prior to and during work, to ensure the technician is aware of potentially toxic or flammable atmospheres. Ensure that the leak detection equipment being used is suitable for use with all applicable refrigerants, i.e. non-sparking, adequately sealed or intrinsically safe.

### **3. Presence of fire extinguisher:**

If any hot work is to be conducted on the refrigerating equipment or any associated parts, appropriate fire extinguishing equipment shall be available to hand. Have a dry powder or CO2 fire extinguisher adjacent to the charging area.

### **4. No ignition sources:**

No person carrying out work in relation to a REFRIGERATING SYSTEM which involves exposing any pipe work shall use any sources of ignition in such a manner that it may lead to the risk of fire or explosion. All possible ignition sources, including cigarette smoking, should be kept sufficiently far away from the site of installation, repairing, removing and disposal, during which refrigerant can possibly be released to the surrounding space. Prior to work taking place, the area around the equipment is to be surveyed to make sure that there are no flammable hazards or ignition risks. "No Smoking" signs shall be displayed.

### **5. Ventilated Area:**

Ensure that the area is in the open or that it is adequately ventilated before breaking into the system or conducting any hot work. A degree of ventilation shall continue during the period that the work is carried out. The ventilation should safely disperse any released refrigerant and preferably expel it externally into the atmosphere.

### **6. Checks to the refrigeration equipment:**

Where electrical components are being changed, they shall be fit for the purpose and to the correct specification. At all times the manufacturer's maintenance and service guidelines shall be followed. If in doubt, consult the manufacturer's technical department for assistance.

The following checks shall be applied to installations using FLAMMABLE REFRIGERANTS:

- The actual REFRIGERANT CHARGE is in accordance with the room size within which the refrigerant containing parts are installed;
- The ventilation machinery and outlets are operating adequately and are not obstructed;
- If an indirect refrigerating circuit is being used, the secondary circuit shall be checked for the presence of refrigerant;
- Marking to the equipment continues to be visible and legible. Markings and signs that are illegible shall be corrected;
- Refrigerating pipe or components are installed in a position where they are unlikely to be exposed to any substance which may corrode refrigerant containing components, unless the components are constructed of materials which are inherently resistant to being corroded or are suitably protected against being so corroded.

### **7. Checks to electrical devices:**

Repair and maintenance to electrical components shall include initial safety checks and component inspection procedures. If a fault exists that could compromise safety, then no electrical supply shall be connected to the circuit until it is satisfactorily dealt with. If the fault cannot be corrected immediately but it is necessary to continue operation, an adequate temporary solution shall be used. This shall be reported to the owner of the equipment so all parties are advised.

Initial safety checks shall include:

- That capacitors are discharged: this shall be done in a safe manner to avoid possibility of sparking;
- That no live electrical components and wiring are exposed while charging, recovering or purging the system;
- That there is continuity of earth bonding.

## **Repairs to Sealed Components**

● During repairs to sealed components, all electrical supplies shall be disconnected from the equipment being worked upon prior to any removal of sealed covers, etc. If it is absolutely necessary to have an electrical supply to equipment during servicing, then a permanently operating form of leak detection shall be located at the most critical point to warn of a potentially hazardous situation.

- Sealed electrical components shall be replaced.

# Maintenance Notice

## Repair to Intrinsically Safe Components

● Do not apply any permanent inductive or capacitance loads to the circuit without ensuring that this will not exceed the permissible voltage and current permitted for the equipment in use.

- Intrinsically safe components must be replaced.
- Replace components only with parts specified by the manufacturer. Other parts may result in the ignition of refrigerant in the atmosphere from a leak.

**NOTE:** The use of silicon sealant can inhibit the effectiveness of some types of leak detection equipment. Intrinsically safe components do not have to be isolated prior to working on them.

## Cabling

Check that cabling will not be subject to wear, corrosion, excessive pressure, vibration, sharp edges or any other adverse environmental effects. The check shall also take into account the effects of aging or continual vibration from sources such as compressors or fans.

## Detection of Flammable Refrigerants

● Under no circumstances shall potential sources of ignition be used in the searching for or detection of refrigerant leaks. A halide torch (or any other detector using a naked flame) shall not be used.

● The following leak detection methods are deemed acceptable for all refrigerant systems.

● Electronic leak detectors may be used to detect refrigerant leaks but, in the case of FLAMMABLE REFRIGERANTS, the sensitivity may not be adequate, or may need re-calibration. (Detection equipment shall be calibrated in a refrigerant-free area.) Ensure that the detector is not a potential source of ignition and is suitable for the refrigerant used. Leak detection equipment shall be set at a percentage of the LFL of the refrigerant and shall be calibrated to the refrigerant employed, and the appropriate percentage of gas (25 % maximum) is confirmed.

● Leak detection fluids are also suitable for use with most refrigerants but the use of detergents containing chlorine shall be avoided as the chlorine may react with the refrigerant and corrode the copper pipe-work.

### NOTE:

Examples of leak detection fluids are

- bubble method,
- fluorescent method agents.

- If a leak is suspected, all naked flames shall be removed/extinguished.
- If a leakage of refrigerant is found which requires brazing, all of the refrigerant shall be recovered from the system, or isolated (by means of shut off valves) in a part of the system remote from the leak.

## Removal and Evacuation

1. When breaking into the refrigerant circuit to make repairs – or for any other purpose – conventional procedures shall be used. However, for flammable refrigerants it is important that best practice be followed, since flammability is a consideration. The following procedure shall be adhered to:

- safely remove refrigerant following local and national regulations;
  - reevacuate;
  - purge the circuit with inert gas (optional for A2L);
  - evacuate (optional for A2L);
  - purge with inert gas (optional for A2L);
  - continuously flush or purge with inert gas when using flame to open circuit, and open the circuit.
2. The refrigerant charge shall be recovered into the correct recovery cylinders if venting is not allowed by local and national codes. For appliances containing flammable refrigerants, the system shall be purged with oxygen-free nitrogen to render the appliance safe for flammable refrigerants. This process might need to be repeated several times. Compressed air or oxygen shall not be used for purging refrigerant systems.
3. For appliances containing flammable refrigerants, refrigerants purging shall be achieved by breaking the vacuum in the system with oxygen-free nitrogen and continuing to fill until the working pressure is achieved, then venting to atmosphere, and finally pulling down to a vacuum (optional for A2L). This process shall be repeated until no refrigerant is within the system (optional for A2L). When the final oxygen-free nitrogen charge is used, the system shall be vented down to atmospheric pressure to enable work to take place.
4. The outlet for the vacuum pump shall not be close to any potential ignition sources, and ventilation shall be available.

## Charging Procedures

1. In addition to conventional charging procedures, the following requirements shall be followed.
- Ensure that contamination of different refrigerants does not occur when using charging equipment. Hoses or lines shall be as short as possible to minimise the amount of refrigerant contained in them.
  - Cylinders shall be kept in an appropriate position according to the instructions.
  - Ensure that the REFRIGERATING SYSTEM is earthed prior to charging the system with refrigerant.
  - Label the system when charging is complete (if not already).
  - Extreme care shall be taken not to overfill the REFRIGERATING SYSTEM.
2. Prior to recharging the system, it shall be pressure-tested with the appropriate purging gas. The system shall be leak-tested on completion of charging but prior to commissioning. A follow up leak test shall be carried out prior to leaving the site.

## Decommissioning

Before carrying out this procedure, it is essential that the technician is completely familiar with the equipment and all its detail. It is recommended good practice that all refrigerants are recovered safely. Prior to the task being carried out, an oil and refrigerant sample shall be taken in case analysis is required prior to re-use of recovered refrigerant. It is essential that electrical power is available before the task is commenced.

- a) Become familiar with the equipment and its operation.
- b) Isolate system electrically.

# Maintenance Notice

## Decommissioning

- c) Before attempting the procedure, ensure that:
- mechanical handling equipment is available, if required, for handling refrigerant cylinders;
  - all personal protective equipment is available and being used correctly;
  - the recovery process is supervised at all times by a competent person;
  - recovery equipment and cylinders conform to the appropriate standards.
- d) Pump down refrigerant system, if possible.
- e) If a vacuum is not possible, make a manifold so that refrigerant can be removed from various parts of the system.
- f) Make sure that cylinder is situated on the scales before recovery takes place.
- g) Start the recovery machine and operate in accordance with instructions.
- h) Do not overfill cylinders (no more than 80 % volume liquid charge).
- i) Do not exceed the maximum working pressure of the cylinder, even temporarily.
- j) When the cylinders have been filled correctly and the process completed, make sure that the cylinders and the equipment are removed from site promptly and all isolation valves on the equipment are closed off.
- k) Recovered refrigerant shall not be charged into another REFRIGERATING SYSTEM unless it has been cleaned and checked.

## Labelling

Equipment shall be labelled stating that it has been de-commissioned and emptied of refrigerant. The label shall be dated and signed. For appliances containing FLAMMABLE REFRIGERANTS, ensure that there are labels on the equipment stating the equipment contains FLAMMABLE REFRIGERANT.

## Recovery

1. When removing refrigerant from a system, either for servicing or decommissioning, it is recommended good practice that all refrigerants are removed safely.
2. When transferring refrigerant into cylinders, ensure that only appropriate refrigerant recovery cylinders are employed. Ensure that the correct number of cylinders for holding the total system charge is available. All cylinders to be used are designated for the recovered refrigerant and labelled for that refrigerant (i.e. special cylinders for the recovery of refrigerant). Cylinders shall be complete with pressure-relief valve and associated shut-off valves in good working order. Empty recovery cylinders are evacuated and, if possible, cooled before recovery occurs.
3. The recovery equipment shall be in good working order with a set of instructions concerning the equipment that is at hand and shall be suitable for the recovery of the flammable refrigerant. If in doubt, the manufacturer should be consulted. In addition, a set of calibrated weighing scales shall be available and in good working order. Hoses shall be complete with leak-free disconnect couplings and in good condition.
4. The recovered refrigerant shall be processed according to local legislation in the correct recovery cylinder, and the relevant waste transfer note arranged. Do not mix refrigerants in recovery units and especially not in cylinders.
5. If compressors or compressor oils are to be removed, ensure that they have been evacuated to an acceptable level to make certain that flammable refrigerant does not remain within the lubricant. The compressor body shall not be heated by an open flame or other ignition sources to accelerate this process. When oil is drained from a system, it shall be carried out safely.

# WIFI Control

## 1. WIFI Module Configura-

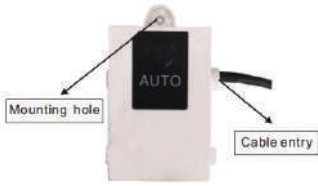
IDU Types	Capacity	WIFI	Function Method
Ceiling Cassette	9, 12, 18, 24 K	✓	 <p><b>WIFI module</b></p> <p><b>Technical parameters:</b></p> <ul style="list-style-type: none"> <li>• Working temperature: 32~122°F (0~50 °C);</li> <li>• Working environment humidity: 20~90%RH;</li> <li>• Dimensions: 78 X 52 X 15.5</li> <li>• Configuration cable wire length: 59 in. (1500 mm)</li> </ul>
Duct	9, 12, 18, 24 K	✓	
Wall Mounted	9, 12, 18, 24 K	✓	Optionally equipped with integrated Wi-Fi

## 2. WIFI Module Configuration

Mobile terminal scans the following intelligent QR code to download APP for IOs or Andoid, or search "AC Freedom" in App Store and Google store.



## 3. Light Commercial WIFI Module Installation

Connect the WIFI module communication wire to WIFI interfaces of main PCB, as shown below:

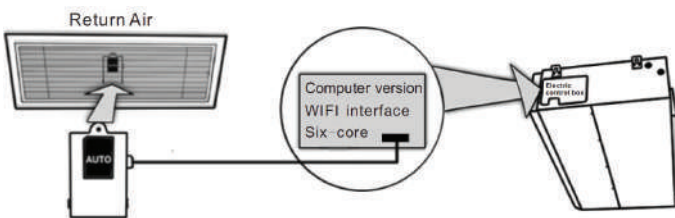

The WIFI module should be placed in the return air or some other place in WIFI area. (Customers should prepare the wireless router)

## 4. Reset AC WIFI Module

In the case of first time configuration or after changing the connected wireless router, the WI-FI module inside the air conditioner needs to be reset.

### NOTE:

The remote control provided in this figure is just one of many models which is for your reference only. Please rely on the model you have actually bought, though the operations are the same for all models.

- If remote controller has "HEALTH" button, reset the WI-FI module as following:  
When AC is running, press "HEALTH" button 8 times, reset successfully after twice "beep" sounds.
- If remote controller has no "HEALTH" button, reset the WI-FI module as following:  
When AC is running, press "COOL"(or SOFT) button and "+" button together for 3s, hear "beep" sound for 8 times, then interval 2s and hear twice "beep" sounds, reset successfully.

## 5. Configure the Devices

After the control software is downloaded and installed on the mobile terminal, configure the AC devices according to the following figure.

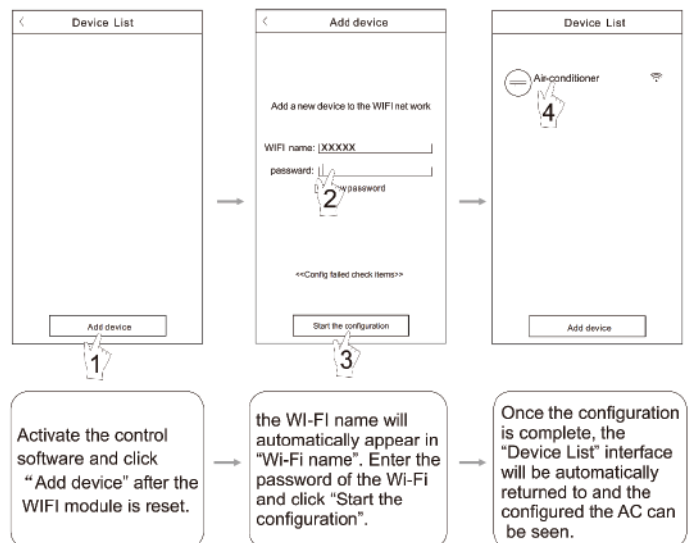

# WIFI Control

## 6. AC Management

### 1. Modify AC name and locking function

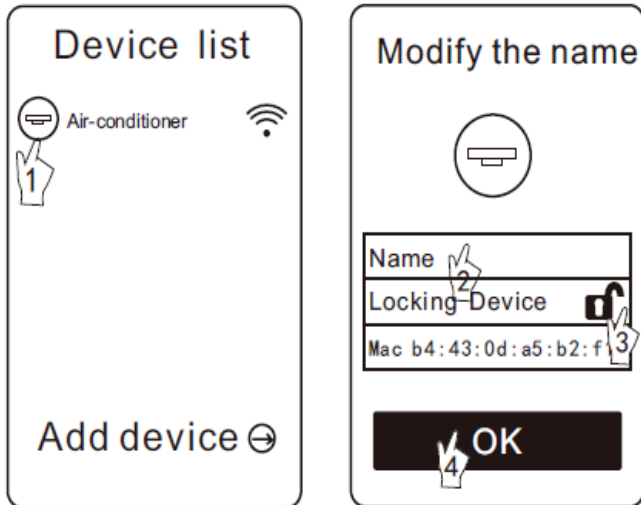

#### NOTE:

If you had locked AC equipment, you need to unlock before connecting other mobile terminal. If the mobile terminal locked AC was accidentally lost, you need to reset WIFI module first, and then use the new mobile terminal to connect (Reset step is same with 1.3 APP configuration).

2. For other instructions, please refer to "HELP" in APP.
3. Remote-control device

Connect the wireless router to internet, then open the GPRS. It means the remote-control device, voice control function only effective after connected to the Internet.

## 7. Config Failed Check Items

1. Please check the Wi-Fi icon on the air conditioner panel, if the icon not display, please contact customer service.
2. Please make sure the mobile phone network under the current router WI-FI environment: Close the mobile phone 3G/4G data connection, to be connected to the router WI-FI pairing.
3. Please check whether the module is reset successfully. For details, see "Reset AC WI-FI module".
4. Please check the Wi-Fi name of the router, it is recommended not to include spaces and other non-alphanumeric characters.
5. Please check the Wi-Fi password of the router, not allowed more than 32 bits, it is recommended not to include spaces and other non-alphanumeric characters.
6. Please check whether the Wi-Fi password input is correct when APP configuration: you can check show password to confirm when you input the WIFI password..

# WARRANTY

**Limited Warranty provided by Comfortside, LLC. (hereby referred to as Comfortside) applies only to registered products installed by a licensed HVAC technician and covers specified products and parts, subject to the following details:**

**Product Registration:** Products must be registered for Limited Warranty within 60 days of installation by licensed HVAC technician. Products can be registered at [armbridge.us](http://armbridge.us). Alternatively, the warranty registration card from the product User's Manual can be filled out and sent in as instructed.

**Warranty Coverage:** The warranty covers the parts of the products which may be defective due to the quality of the materials or workmanship, under normal use and proper maintenance. Warranty is provided only to the first original owner of the Product, where it is originally installed, and is not transferable to the subsequent owners.

**Warranty Exclusions:** Comfortside is not responsible for any warranty claim:

1. For equipment installed outside of North America.
2. For equipment not installed according to manufacturer's guidelines.
3. For equipment which has been removed from the original site of installation and reinstalled at another location.
4. If registration information cannot be verified (i.e., invalid license number or wrong information provided).
5. Regarding damages or repairs arising as a result of a faulty installation, inappropriate application, or improper use.
6. Regarding damages or repairs arising from any external perils, out of Comfortside's control, acts of nature such as fires, storms, accidents, floods, broken or frozen water pipes, electrical surges, input power with under or overvoltage, lightning, or existence of corrosive substances nearby.
7. Regarding damages or repairs arising from use of non-compatible parts, third-party components, alterations, modifications, or improper applications.
8. Regarding improper service or poor maintenance of the equipment, such as cleaning of all air filters, heat exchangers, fans, and blowers, in addition to any necessary lubrication of internal components and maintenance of external accessories.
9. Regarding changes that can be considered cosmetic, including but not limited to small fin damages, scratches on the unit cover, etc.
10. Regarding resetting of power or the circuit breakers and replacement of other types of fuses, both internal and external.
11. Regarding any damage caused using dirty, recycled, or wrong type of refrigerants and lubricants.
12. Regarding damage due to moisture, air, dust, sand, dirt, etc., that have been allowed into the system.
13. Regarding damage caused by continuing use of the product after a malfunction has been noticed or indicated at the display module, through an error code.
14. Regarding damages or performance issues due to improper matching, product selection, under-sizing, over-sizing, improper installation, or misuse.
15. Regarding loss or replacement of refrigerant, lubricant, or oil.
16. Regarding labor or any costs associated with labor.

**Warranty Begin Date:** Warranty begins on the date of registration.

**Warranty End Date:** Products that have not been registered as instructed above are not covered under Warranty. The length of your Warranty depends on the specific model unit you have purchased. Information on Warranty length is available online, by visiting [armbridge.us](http://armbridge.us). As further explained below in detail, coverage is only for the original registered user who owns and resides in the dwelling or operates business in the property in which the product is installed.

# WARRANTY

**Remaining Warranty:** Any part, component or product that is replaced under the terms of the Warranty, will be covered under the same Warranty for the duration in which the original Warranty for the product is applicable.

**Warranty Procedure:** Comfortside will furnish a new or refurbished part, without any charge for the part itself, for the replacement of any part that has been determined to have failed, by Comfortside at its sole discretion, due to defects in its materials or workmanship under standard use and proper maintenance. The payment of the shipping costs for the part will be the sole responsibility of the owner of the product. Comfortside reserves the right to ask the owner of the product to return the failed part before or after a replacement part is sent out. The product owner or technician should contact Comfortside Technical Support at (800) 977-0722, Monday to Friday from 9AM to 8PM Eastern Time, while the technician is on site, servicing the unit. The product may or may not display error codes. The technician should be on site while troubleshooting with the Comfortside Technical Support Agent so he or she can address symptoms observed, specific electrical and mechanical measurements, and other detailed information that may be required for proper diagnosis.

While technicians may refer to Comfortside's website or YouTube channel for helpful information, such as manuals and videos based on certain error codes, the technician will need to troubleshoot with the Technical Support Agent for Warranty purposes. Comfortside is not able to remotely diagnose a product and or offer remedies, without proper diagnosis results.

When contacting Technical Support, a licensed technician must be onsite, and the following information needs to be provided:

- The Serial Number of the unit.
- The product purchase invoice and an installation invoice from licensed HVAC technician.
- Case number (if applicable) provided during previous Technical Support call(s).
- Comfortside may ask for photos and/or other diagnostic information it deems necessary prior to processing the Warranty claim.

It should be noted that Comfortside Technical Support Agents troubleshoot on a case-by-case basis, following best practices and procedures to diagnose problems and solutions. Through this process, it is most efficient to diagnose one issue or error code at a time. It is possible that the first suggested solution may or may not solve one problem of multiple failures, in which case the Technician will continue through troubleshooting for remaining issues/error codes.

**Labor cost, materials, and other costs:** Any labor costs and/or the costs for the supplies or materials used or purchased in the field for the replacement of the defective part, remain the responsibility of the owner. No other costs involved in diagnosis, lodging, transportation, servicing, repair, replacement, installation, removal, shipping, etc., are to be covered under the Warranty.

**Refrigerant:** Any costs related to charging, recharging, adjustment, or removal of refrigerant, and the cost of the refrigerant itself, are not covered under any circumstances. All products go through vigorous quality

Comfortside does not cover any claims related to the lack of refrigerant in new products, discovered upon arrival, or during installation, as well as subsequent refrigerant loss occurring at any time afterward.

# WARRANTY

This Warranty is not transferable. No person or entity is authorized to change the terms and conditions outlined in this Warranty agreement, in any respect, nor to create any additional obligations or liabilities for any party involved.

This warranty agreement supersedes all prior warranty agreements between the parties and constitutes the complete, final, and exclusive understanding of the parties with respect to the subject matter. All prior negotiations, representations, or promises, whether oral or written, of either party shall be deemed to have been merged herein.

If any part of this Warranty Agreement shall be invalidated for any reason, such part shall be deleted, and the remainder shall be unaffected and shall continue in full force and effect. This Warranty provides you certain legal rights and you may also have other rights, which vary from State to State. Therefore, some of these limitations or exclusions may not apply to you.

**States with Express and Implied Warranties:** Products in states with Express and Implied Warranties do not need to be registered for Comfortside Warranty. However, for Warranty support, installation invoice should be provided.

## **Pursuing legal remedies:**

**ARBITRATION CLAUSE. IMPORTANT. PLEASE REVIEW THIS ARBITRATION CLAUSE, AS IT AFFECTS YOUR LEGAL RIGHTS.**

1. This arbitration clause affects your rights against Comfortside and any of its employees, agents, affiliates, successors, or assignees, all of whom together are referred to below as “we” or “us” for the simplicity of reference.
2. **ARBITRATION REQUIREMENT; EXCEPT AS STATED BELOW, ANY DISPUTE BETWEEN YOU AND ANY OF US SHALL BE DECIDED BY NEUTRAL AND BINDING ARBITRATION, RATHER THAN ANY COURT OR BY TRIAL BY JURY. ARBITRATION WILL BE HANDLED ONLY ON AN INDIVIDUAL BASIS AND ALL PARTIES EXPRESSLY WAIVE; ANY RIGHTS TO PARTICIPATE AS A CLASS REPRESENTATIVE OR CLASS MEMBER, ANY RIGHTS TO CLASS ARBITRATION OR ANY CONSOLIDATION OF INDIVIDUAL ARBITRATIONS. THE ARBITRATOR WILL BE A MEMBER OF THE AMERICAN ARBITRATION ORGANIZATION.** The meaning of “Dispute” has the broadest possible meaning allowable by law, including any controversy, claim or other dispute, relating to or arising from the purchase of the product, any of the warranties upon the product, or the condition of the product, as well as the determination of the application or the scope of the Arbitration Clause itself. Rights to appeal and discovery are also limited in arbitration based on the rules of the arbitration organizations.
3. **Governing Law:** Effect and procedures of arbitration will be governed by the Federal Arbitration Act (9 U.S.C. § et seq.) rather than any related state law. In case of any substantive warranty, your claims and rights under such substantive warranty will be governed by the applicable law of the state in which Product was purchased.
4. **Location of the Arbitration:** Unless otherwise provided under the applicable law, arbitration hearing will be conducted in the judicial district in Miami-Dade County, Florida.
5. **Costs of the Arbitration:** Unless otherwise provided under the applicable law, each party will be responsible for its own cost, payable to the arbitration organization, and the costs of their attorneys, experts or other fees.
6. **Survival and Enforceability of the Arbitration Clause:** This arbitration clause will survive the expiration or termination of this warranty agreement, indefinitely.



## DE-COMMISSIONING,DISMANTLING&DISPOSAL

This product contains refrigerant under pressure, rotating parts, and electrical connections which may be a danger & cause injur. All work must only be carried out by competent persons using suitable protective clothing and safety precautions.



Read the Manual



Risk of Electric Shock

**RoHS**



Unit is Remotely controlled  
& may start without warning



1. Isolate all sources of electrical supply to the unit including any control system supplies switched by the unit. Ensure that all points of electrical and gas isolation are secured in the OFF position. The supply cables and gas pipe work may then be disconnected and removed. For points of connection refer to unit installation instructions.
2. Remove all refrigerant from each system of the unit into a suitable container using a refrigerant reclaim or recovery unit. This refrigerant may then be reused, if appropriate, or returned to the manufacturer for disposal. Under no circumstances should refrigerant be vented to atmosphere Where appropriate, drain the refrigerant oil from each system into a suitable container and dispose of according to local laws and regulations governing disposal of oily wastes.
3. Packaged units can generally be removed in one piece after disconnection as above. Any fixing down bolts should be removed and then unit lifted from position using the points provided and equipment of adequate lifting capacity. Reference **MUST** be made to the unit installation instructions for unit weight and correct methods of lifting. Note that any residual or spilt refrigerant oil should be mopped up and disposed of as described above.
4. After removal from position the unit parts may be disposed of according to local laws and regulations.
5. Meaning of crossed Out wheeled dustbin: Do not dispose of electrical appliances as unsorted municipal waste, use separate collection facilities. Contact your local government for information regarding the collection systems available. If electrical appliances are disposed of in landfills or dumps, hazardous substances can leak into the groundwater and get into the food chain, damaging your health and well being. When replacing old appliances with new ones, the retailer is legally obligated to take back your old appliance for disposals at least free of charge.

Made in China





**05302025**

Made in China